

## Front Suspension:

Ride Height: \_\_\_\_\_  
 Camber: \_\_\_\_\_  
 Toe: \_\_\_\_\_  
 Anti-Roll Bar: \_\_\_\_\_  
 Arm Type: \_\_\_\_\_  
 Wheelbase Shim: \_\_\_\_\_  
 Wheel Hex: \_\_\_\_\_  
 Caster Block: 8°  9°  10°   
 Chassis Brace: Plastic  Carbon   
 Top Plate Brace: Yes  No   
 Front Axles: CVA  DCV   
 Notes: \_\_\_\_\_



Front Chassis Brace Screws: \_\_\_\_\_

Ball Stud Spacing: \_\_\_\_\_



Arm Mount A: 1°  0.5°



Arm Mount B: 1°  0.5°



Diff Height:

+3
+2
+1
0

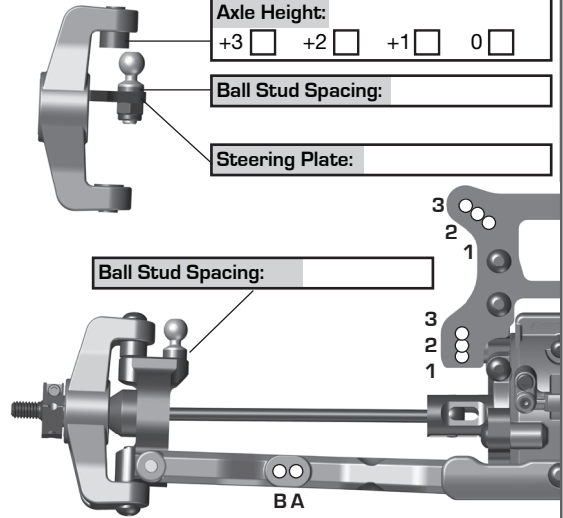

## Rear Suspension:

Ride Height: \_\_\_\_\_  
 Camber: \_\_\_\_\_  
 Anti-Roll Bar: \_\_\_\_\_  
 Arm Type: \_\_\_\_\_  
 Wheelbase Shim: \_\_\_\_\_  
 Wheel Hex: \_\_\_\_\_  
 CVA Bone Length: \_\_\_\_\_  
 Chassis Brace: Plastic  Carbon   
 Hub Spacing: Fwd  Mid  Back   
 Notes: \_\_\_\_\_

Rear Chassis Brace Screws: \_\_\_\_\_

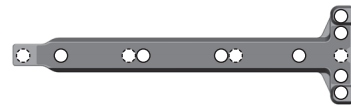

Arm Mount C: 1°  0.5°



Arm Mount D: 1°  0.5°



Diff Height:

+3
+2
+1
0

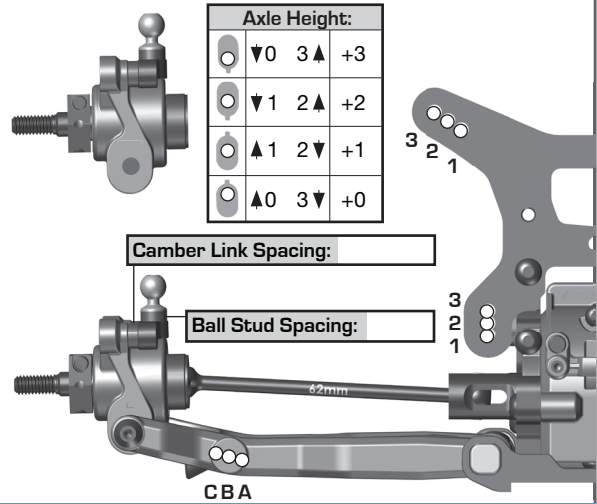

## Electronics:

Radio: \_\_\_\_\_ Servo: \_\_\_\_\_  
 EPA: Throttle: % Brake: %  
 ESC: \_\_\_\_\_  
 ESC Settings: \_\_\_\_\_  
 Motor: \_\_\_\_\_  
 Wind: \_\_\_\_\_ Timing: \_\_\_\_\_  
 Pinion: \_\_\_\_\_ Spur: \_\_\_\_\_  
 Battery: \_\_\_\_\_  
 Battery Position: 1  2  3  4

## Differential:

Front Fluid: \_\_\_\_\_ Mass: \_\_\_\_\_  
 Gears: Plastic  Metal   
 Center Fluid: \_\_\_\_\_ Mass: \_\_\_\_\_  
 Gears: Plastic  Metal   
 Rear Fluid: \_\_\_\_\_ Mass: \_\_\_\_\_  
 Gears: Plastic  Metal   
**Slipper Clutch:**  
 Setting: \_\_\_\_\_  
 Pads: \_\_\_\_\_

## Shocks:

	Front	Rear
Piston:		
Fluid:		
Spring:		
Limiters:		
Stroke:		
Eyelet Length:		
Cup Offset:		
Notes:		

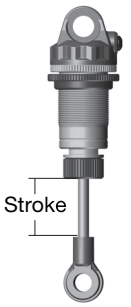

## Track Info:

Size: Small  Medium  Large  Extra Large   
 Surface: Dirt  Carpet  AstroTurf  Multi Surface   
 Traction: Low  Medium  High  Very High   
 Moisture: Dry  Damp  Wet   
 Condition: Indoor  Outdoor  Dusty  Hard Packed   
 Bumpy  Grooved  Smooth  Loamy   
 Temperature: Ambient: \_\_\_\_\_ Track: \_\_\_\_\_  
 Notes: \_\_\_\_\_

## Tires:

Front Tires: \_\_\_\_\_  
 Front Compound: \_\_\_\_\_  
 Front Insert: \_\_\_\_\_  
 Rear Tires: \_\_\_\_\_  
 Rear Compound: \_\_\_\_\_  
 Rear Insert: \_\_\_\_\_  
 Wheel (F/R): \_\_\_\_\_  
 Notes: \_\_\_\_\_

## Body, Wing, Weight:

Body: \_\_\_\_\_  
 Wing: \_\_\_\_\_  
 Front Wing: Yes  No   
 Wing Angle: 0°  6°   
 Weights: \_\_\_\_\_  
 Total Vehicle Weight: \_\_\_\_\_

## Vehicle Comments:

Notes: \_\_\_\_\_