

STAMPEDE

4x4

MODEL 67010-4



TRAXXAS

ASSEMBLY MANUAL



FIRE HAZARD! Your model is able to use LiPo batteries. Charging and discharging batteries has the potential for fire, explosion, serious injury, and property damage if not performed per the instructions. Before use, read and follow all manufacturer's instructions, warnings, and precautions. In addition, Lithium Polymer (LiPo) batteries pose a SEVERE risk of fire if not properly handled per the instructions and require special care and handling procedures for long life and safe operation. LiPo batteries are intended only for advanced users that are educated on the risks associated with LiPo battery use. Traxxas does not recommend that anyone under the age of 14 use or handle LiPo battery packs without the supervision of a knowledgeable and responsible adult. Dispose of used batteries according to the instructions.

Important Warnings for users of Lithium Polymer (LiPo) batteries:

- LiPo batteries have a minimum safe discharge voltage threshold that should not be exceeded. The electronic speed control is equipped with built-in Low-Voltage Detection that alerts the driver when LiPo batteries have reached their minimum voltage (discharge) threshold. It is the driver's responsibility to stop immediately to prevent the battery pack from being discharged below its safe minimum threshold.
- Low-Voltage Detection is just one part of a comprehensive plan for safe LiPo battery use. It is critical to follow all instructions for safe and proper charging, use, and storage of LiPo batteries. Make sure you understand how to use your LiPo batteries. If you have questions about LiPo battery usage, please consult with your local hobby dealer or contact the battery manufacturer. As a reminder, all batteries should be recycled at the end of their useful life.
- ONLY use a Lithium Polymer (LiPo) balance charger with a balance adapter port to charge LiPo batteries. Never use NiMH or NiCad-type chargers or charge modes to charge LiPo batteries. DO NOT charge with a NiMH-only charger. The use of a NiMH or NiCad charger or charge mode will damage the batteries and may cause fire and personal injury.
- NEVER charge LiPo battery packs in series or parallel. Charging packs in series or parallel may result in improper charger cell recognition and an improper charging rate that may lead to overcharging, cell imbalance, cell damage, and fire.
- ALWAYS inspect your LiPo batteries carefully before charging. Look for any loose leads or connectors, damaged wire insulation, damaged cell packaging, impact damage, fluid leaks, swelling (a sign of internal damage), cell deformity, missing labels, or any other damage or irregularity. If any of these conditions are observed, do not charge or use the battery pack. Follow the disposal instructions included with your battery to properly and safely dispose of the battery.
- DO NOT store or charge LiPo batteries with or around other batteries or battery packs of any type, including other LiPos.
- Store and transport your battery pack(s) in a cool dry place. DO NOT store in direct sunlight. DO NOT allow the storage temperature to exceed 140°F or 60°C, such as in the trunk of a car, or the cells may be damaged and create a fire risk.
- DO NOT disassemble LiPo batteries or cells.
- DO NOT attempt to build your own LiPo battery pack from loose cells.

Charging and handling precautions for all battery types:

- BEFORE you charge, ALWAYS confirm that the charger settings exactly match the type (chemistry), specification, and configuration of the battery to be charged.

WARNING! CAUTION! DANGER!



- DO NOT attempt to charge non-rechargeable batteries (explosion hazard), batteries that have an internal charge circuit or a protection circuit, batteries that have been altered from original manufacturer configuration, or batteries that have missing or unreadable labels, preventing you from properly identifying the battery type and specifications.
- DO NOT exceed the maximum manufacturer recommended charge rate.
- DO NOT let any exposed battery contacts or wires touch each other. This will cause the battery to short circuit and create the risk of fire.
- While charging or discharging, ALWAYS place the battery (all types of batteries) in a fire retardant/fire proof container and on a non-flammable surface such as concrete.
- DO NOT charge batteries inside of an automobile. DO NOT charge batteries while driving in an automobile.
- NEVER charge batteries on wood, cloth, carpet, or on any other flammable material.
- ALWAYS charge batteries in a well-ventilated area.
- REMOVE flammable items and combustible materials from the charging area.
- DO NOT leave the charger and battery unattended while charging, discharging, or anytime the charger is ON with a battery connected. If there are any signs of a malfunction or in the event of an emergency, unplug the charger from the power source and disconnect the battery from the charger.
- DO NOT operate the charger in a cluttered space, or place objects on top of the charger or battery.
- If any battery or battery cell is damaged in any way, DO NOT charge, discharge, or use the battery.
- Keep a Class D fire extinguisher nearby in case of fire.
- DO NOT disassemble, crush, short circuit, or expose the batteries to flame or other source of ignition. Toxic materials could be released. If eye or skin contact occurs, flush with water.
- If a battery gets hot to the touch during the charging process (temperature greater than 110°F / 43°C), immediately disconnect the battery from the charger and discontinue charging.
- Allow the battery pack to cool off between runs (before charging).
- ALWAYS unplug the charger and disconnect the battery when not in use.
- ALWAYS unplug the battery from the electronic speed control when the model is not in use and when it is being stored or transported.
- DO NOT disassemble the charger.
- REMOVE the battery from your model or device before charging.
- DO NOT expose the charger to water or moisture.
- ALWAYS store battery packs safely out of the reach of children or pets. Children should always have adult supervision when charging and handling batteries.
- Nickel-Metal Hydride (NiMH) batteries must be recycled or disposed of properly.
- Always proceed with caution and use good common sense at all times.

All of us at Traxxas want you to safely enjoy your new model. Operate your model sensibly and with care, and it will be exciting, safe, and fun for you and those around you. Failure to operate your model in a safe and responsible manner may result in property damage and serious injury. The precautions outlined in this manual should be strictly followed to help ensure safe operation. You alone must see that the instructions are followed and the precautions are adhered to.

Important Points to Remember

- Your model is not intended for use on public roads or congested areas where its operation can conflict with or disrupt pedestrian or vehicular traffic.
- Never, under any circumstances, operate the model in crowds of people. Your model is very fast and could cause injury if allowed to collide with anyone.
- Because your model is controlled by radio, it is subject to radio interference from many sources that are beyond your control. Since radio interference can cause momentary losses of radio control, always allow a safety margin in all directions around the model in order to prevent collisions.
- The motor, battery, and speed control can become hot during use. Be careful to avoid getting burned.
- Don't operate your model at night, or anytime your line of sight to the model may be obstructed or impaired in any way.

Speed Control

Your model's electronic speed control (ESC) is an extremely powerful electronic device capable of delivering high current. Please closely follow these precautions to prevent damage to the speed control or other components.

- **Disconnect the Battery:** Always disconnect the battery or batteries from the speed control when not in use.
- **Insulate the Wires:** Always insulate exposed wiring with heat shrink tubing to prevent short circuits.
- **Transmitter on First:** Switch on your transmitter first before switching on the speed control to prevent runaways and erratic performance.
- **Don't Get Burned:** The ESC and motor can become extremely hot during use, so be careful not to touch them until they cool. Supply adequate airflow for cooling.
- **Use the Factory-Installed Connectors:** Do not change the battery and motor connectors. Improper wiring can cause fire or damage to the ESC. Please note that modified speed controls can be subject to a rewiring fee when returned for service.

- **No Reverse Voltage:** The ESC is not protected against reverse polarity voltage.
- **No Schottky Diodes:** External Schottky diodes are not compatible with reversing speed controls. Using a Schottky diode with your Traxxas speed control will damage the ESC and void the 30-day warranty.
- **Always** adhere to the minimum and maximum limitations of the speed control as stated in the specifications table in the Owner's Manual. If your ESC operates on two batteries, do not mix battery types and capacities. Use the same voltage and capacity for both batteries. Using mismatched battery packs could damage the batteries and electronic speed control.

Recycling Traxxas Power Cell NiMH Batteries

Traxxas strongly encourages you to recycle Power Cell NiMH batteries when they reach the end of their useful life. Do not throw batteries in the trash. All Power Cell NiMH battery packs display the RBRC (Rechargeable Battery Recycling Corporation) icon, indicating they are recyclable. To find a recycling center near you, ask your local hobby dealer or visit www.call2recycle.org.

Thank you for purchasing the Traxxas Stampede 4x4 unassembled kit. Whether you're going through muddy water crossings or just having fun crushing your buddies' cars, the Stampede 4x4 just doesn't know when to quit. The Stampede 4x4 is overbuilt and Traxxas Tough to withstand all the 4-wheel drive monster mayhem you can dish out. Its tall, drive-over-anything ground clearance and ultra-tough, long-arm suspension make Stampede 4x4 feel nearly indestructible. Chrome All-Star™ 2.8" wheels give Stampede 4x4 aggressive style, and soft Chevron Maxx™ tires deliver true multi-terrain capability.

This manual details the assembly of the Stampede 4x4. This manual will also acquaint you with the model's many different components and its mechanical operation. Read through the manual and examine the model carefully before opening any of the parts bags included in the kit. If for some reason you think the model is not what you wanted, then do not continue any further. Your hobby dealer absolutely cannot accept a model for return or exchange which has been run or contains open bags.

If you have any questions about your Stampede 4x4, call Traxxas' technical support department at 1-888-TRAXXAS (1-888-872-9927) (U.S. residents only). Outside the U.S., call +1-972-549-3000. Technical support is available Monday through Friday, from 8:30am to 9:00pm central time. Technical assistance is also available at Traxxas.com/support or via e-mail at support@Traxxas.com.

Join thousands of registered members in our online community at Traxxas.com. Traxxas offers a full-service, on-site repair facility to handle any of your Traxxas service needs. Maintenance and replacement parts may be purchased directly from Traxxas by phone or online at Traxxas.com. You can save time, along with shipping and handling costs, by purchasing replacement parts from your local dealer. Do not hesitate to contact us with any of your product support needs. We want you to be thoroughly satisfied with your new model!

ASSEMBLY HINTS

To assemble this kit, you'll need a large flat working area where you will have plenty of room to build. Be sure it's a place where you can leave your work spread out and not in the way when you want to take a break from the assembly. Allow yourself plenty of time to build this kit; assembly time is going to vary with each individual. Experienced builders may only need 4-5 hours to assemble this kit, while others may spend an entire weekend on it. You should feel comfortable with taking as much time as needed to properly build and set up your model.

If you've been exploring the contents of your kit box, you've noticed many bags of small parts. Open only one bag at a time. To keep the parts organized, use small paper plates or several large plastic plates with partitions to contain the parts. Label the paper plates, and then pour the contents of the bags onto them. This puts the parts out in the open where you can find them easily. The plates also prevent small parts from rolling off the table.

Please read the text next to each diagram. The text contains important information, such as assembly steps, screw sizes, and part numbers. Also, pay attention to any notes that may follow some steps. Before you attempt to run your newly-built model, please read all of the instructions and precautions included in the Owner's Manual. You can download the Owner's Manual for the Stampede 4x4, as well as the manuals for all Traxxas vehicles, at Traxxas.com.

Remember, as you assemble your Traxxas model, you are not alone. If you have any questions or run into difficulties, call Traxxas' technical support department at 1-888-TRAXXAS (1-888-872-9927) (U.S. residents only). Outside the U.S., call +1-972-549-3000. Technical support is available Monday through Friday, from 8:30am to 9:00pm central time.

ITEMS YOU WILL NEED

Some of the tools that you may need in the maintenance and repair of your model have been provided. These include:

- 1.5mm "L" wrench
- 2.0mm "L" wrench
- 2.5mm ball wrench
- 4-way wrench
- U-joint wrench
- 4mm / 8mm wrench

Required but not included:

- Radio system with transmitter, receiver, and servo
- Power system with motor and speed control
- Traxxas Ultra Premium Tire Glue (CA glue) (part #6468)
- 4 AA alkaline batteries
- NiMH battery pack or LiPo battery pack
- NiMH/LiPo battery charger
- Safety glasses
- Needle nose pliers

The following items are not required for the operation of your model, but are a good idea to include in any RC toolbox:

- Metric hex driver set (part #3415)
(highly recommended for kit assembly)
- Hobby knife
- Side cutters

These items can be purchased from your hobby dealer.

SELECTING A CHARGER AND BATTERIES FOR YOUR MODEL

Your model does not include a battery or charger. Traxxas Power Cell iD batteries are strongly recommended for maximum performance and safer charging. The following chart lists available Power Cell batteries for your model:

LiPo Batteries with iD

- 2843X** 5800mAh 7.4V 2-Cell 25C LiPo Battery
- 2854X** 10000mAh 7.4V 2-Cell 25C LiPo Battery

NiMH Batteries with iD

- 2926X** Battery, Power Cell, 3000mAh (NiMH, 7-C hump, 8.4V)
- 2941X** Battery, Series 3 Power Cell, 3300mAh (NiMH, 7-C hump, 8.4V)
- 2951X** Battery, Series 4 Power Cell, 4200mAh (NiMH, 7-C hump, 8.4V)
- 2961X** Battery, Series 5 Power Cell, 5000mAh (NiMH, 7-C hump, 8.4V)



WARNING: FIRE HAZARD!

Users of Lithium Polymer (LiPo) batteries must read the Warnings and Precautions beginning on page 2. You **MUST** use a LiPo charger for LiPo batteries or battery damage with the potential for fire will result.

Make certain you choose the correct type of charger for the batteries you select. Traxxas recommends you choose a genuine Traxxas EZ-Peak iD charger for safer charging and maximum battery life and performance.

Charger	Part No.	NiMH Compatible	LiPo Compatible	Battery iD	Max. Cells
EZ-Peak Plus, 4 amps	2970	YES	YES	YES	3s
EZ-Peak Live, 12 amps	2971	YES	YES	YES	4s
EZ-Peak Dual, 8 amps	2972	YES	YES	YES	3s
EZ-Peak Live Dual, 26+amps	2973	YES	YES	YES	4s

SELECTING A RADIO SYSTEM FOR YOUR MODEL

Your model does not include a transmitter, receiver, or servo. Traxxas TQi radio systems are recommended for best performance. The following chart lists available choices for your model:

Radio Systems

- 6507R** TQi 2.4 GHz High Output radio system, 4-channel with Traxxas Link Wireless Module, TSM (4-ch transmitter, 5-ch micro receiver)
- 6509R** TQi 2.4 GHz High Output radio system, 2-channel, Traxxas Link enabled, TSM (2-ch transmitter, 5-ch micro receiver)
- 6516** Transmitter, TQ 2.4GHz, 2-channel (transmitter only)
- 6519** Receiver, micro, TQ 2.4GHz (3-channel)

Servos

- 2056** Servo, high-torque, waterproof (blue case)
- 2075** Servo, digital high-torque (ball bearing), waterproof
- 2075R** Servo, digital high-speed, metal gear (ball bearing), waterproof
- 2250** Servo, digital high-torque 330 coreless, metal gear (ball bearing), waterproof
- 2255** Servo, digital high-torque 400 brushless, metal gear (ball bearing), waterproof

SELECTING A POWER SYSTEM FOR YOUR MODEL

Your model does not include a motor or electronic speed control. Traxxas power systems are recommended for best performance. The following chart lists available choices for your model:

Electronic Speed Controls

- 3018R** XL-5 Electronic Speed Control, waterproof (land version, low-voltage detection, fwd/rev/brake)
- 3355R** Velineon VXL-3s Electronic Speed Control, waterproof (brushless) (fwd/rev/brake)

Motors

- 3785** Motor, Titan 12T (12-Turn, 550 size)
- 3351R** Motor, Velineon 3500, brushless (assembled with 12-gauge wire and gold-plated bullet connectors)

WARRANTY STATEMENT









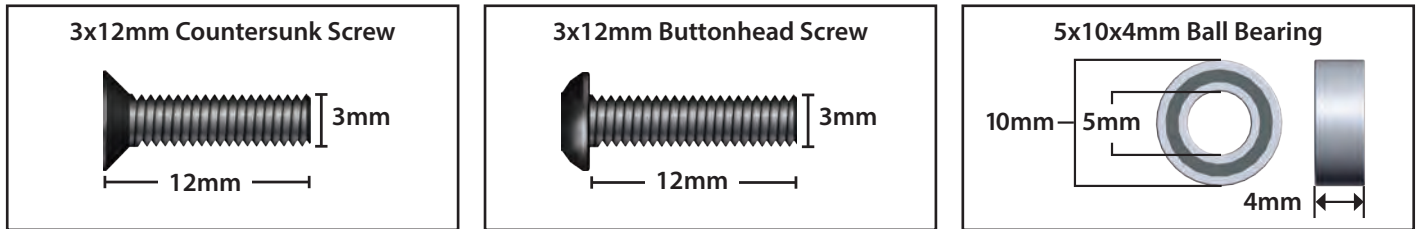

Every effort has been made in component design and material selection to make your model as durable as possible and still maintain a weight consistent with good handling. Because this model is intended for operation under severe conditions, no warranties are expressed nor implied relating to the longevity of the parts. If you find that a part has a defect in materials or workmanship, please return it to us **BEFORE IT IS USED**, and we will gladly replace it. Damage caused by excessive force, abuse, neglect or failure to adhere to the precautions outlined in the literature contained with your model will void the warranty.

INTRODUCTION

HARDWARE DESCRIPTIONS







The following chart is provided to help you identify the many different sizes and types of hardware that are used in the assembly of this model. Note the difference between the length measurements of the roundhead and countersunk screws. A ruler is provided at the bottom of each page to measure the length of the screws in millimeters.



 CCS Countersunk Cap Screw	 GS Set (Grub) Screw
 CS Cap Screw	 PTW PTFE Washer
 FCS Flathead Cap Screw	 MW Metal Washer
 BCS Buttonhead Cap Screw	 E E-Clip
 CSS Cap Shoulder Screw	 BB Ball Bearing
 NL Nylon Locknut	

ICON DESCRIPTIONS

There are icons in this assembly instruction which indicate certain actions needed during assembly.

 <p>Grease Tube Apply included grease to part indicated. <i>White: Silicone</i> <i>Dark: Black Lithium</i></p>	 <p>Turn Icon Indicates assembly needs to be flipped or turned around.</p>	 <p>Oil Bottle <i>Black:</i> Use included silicone shock oil. <i>White:</i> Use included differential fluid.</p>
 <p>Repeat Icon Repeat step the number of times indicated.</p> 	 <p>Optional Part Icon Optional part available. Refer to included parts list.</p>	 <p>Aluminum Part Icon Aluminum accessory part available. Refer to included parts list.</p>

A. DIFFERENTIAL ASSEMBLY

DIFFERENTIAL BAG

Differential Carrier

30K Differential Oil

Differential Output Gear (2)



6x9.5x0.5 PTFE Washer



X-Ring (2)



Differential Gasket

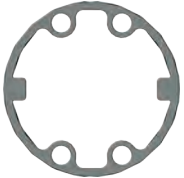

Spider Gear (2)

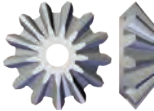

Spider Gear Shaft



Ring Gear



2.5x8mm CS (4)



8x16x5mm BB

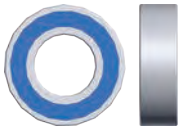

10x15x4mm BB



A1. Install output and spider gears into differential carrier

Tip: Lubricate the shaft of the differential output gear with a drop of 30K differential oil before installing the X-ring.



x2

Spider gear assembly

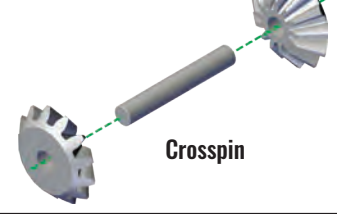

Differential Gasket



Spider Gear Assembly



A2. Add differential fluid

Fill differential carrier half way with included 30K differential oil.

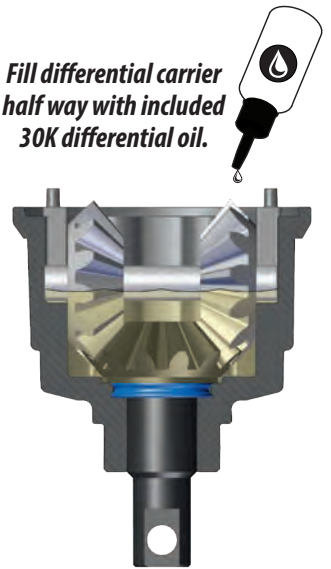

x2

A3. Install output gear into ring gear and assemble onto differential carrier

Tip: Lubricate the shaft of the differential output gear with a drop of 30K differential oil before installing the X-ring.

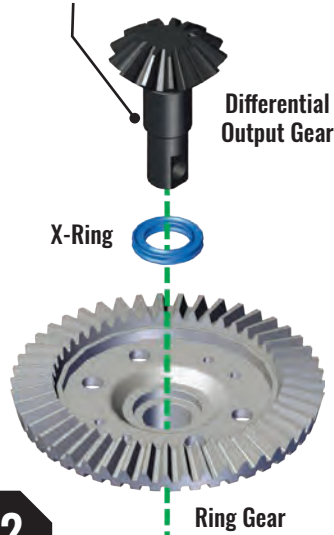

x2

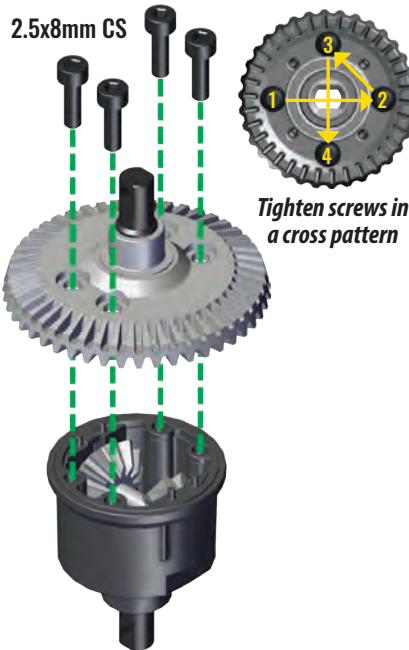

A4. Install ball bearings

8x16x5 BB



x2

Completed differential assemblies

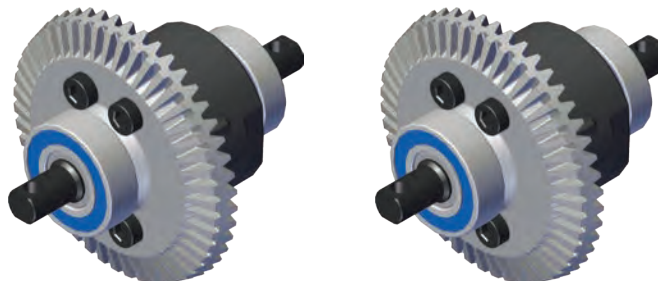

ACCESSORY

Option Part
5379X Ring gear, differential/
pinion gear, differential for
brushless models

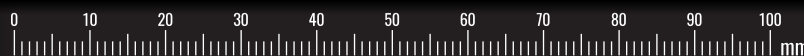

B. SHOCK ASSEMBLY

SHOCK BAG

- Shock Assemblies
- Silicone Shock Oil
- Front Shock Springs
- Rear Shock Springs
- Upper Spring Retainers (4)
- Lower Spring Retainers (4)
- Preload Spacers (2)

B1. Assemble front and rear shocks

x4

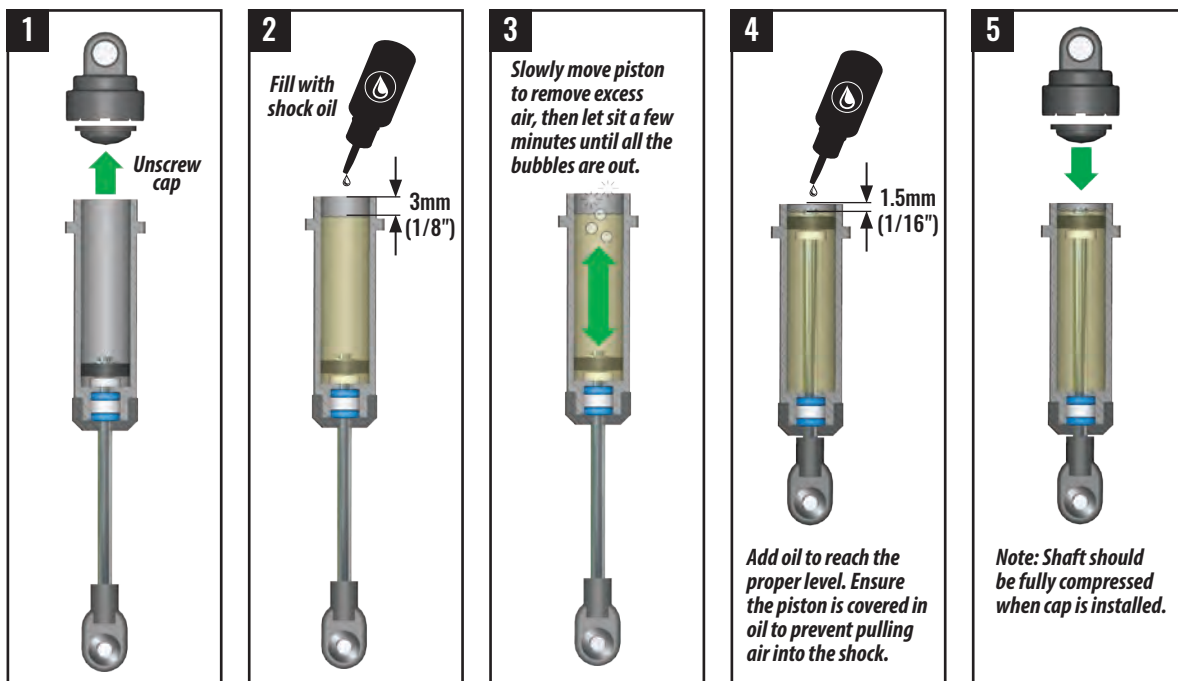

Shock Exploded View

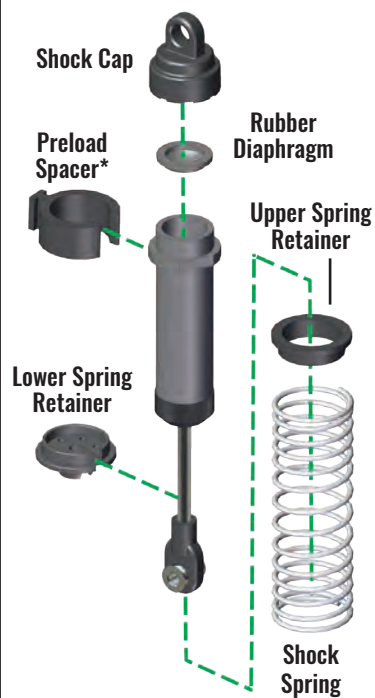

Exercise shock to make sure it compresses fully. If it does not, it is overfilled.

Front Shocks Assembled

Rear Shocks Assembled

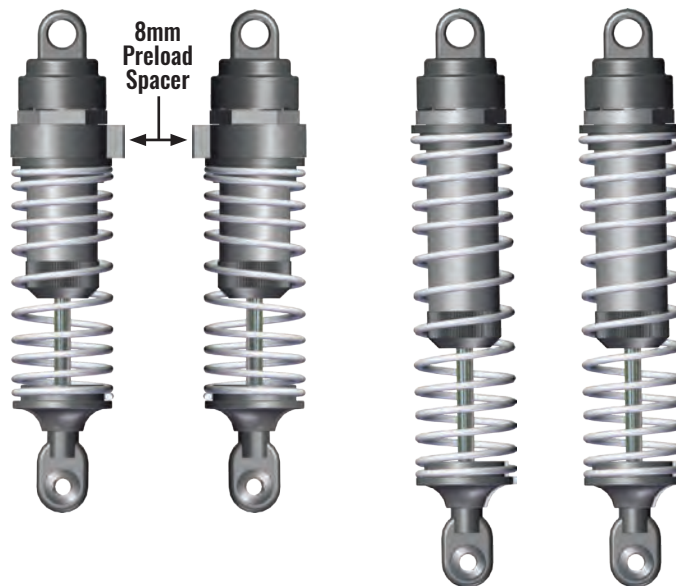

ACCESSORY

- A** Aluminum Accessory
Aluminum Shock Caps
3767A - Blue
3767G - Green
3767X - Red
- O** Option Part
Titanium Nitride
Shock Shafts
1664T Long
2656T XX-long

*8mm preload spacer on front shocks only



C. FRONT MODULE ASSEMBLY

FRONT BULKHEAD BAG

Front Differential Housing

Front Bulkhead

4x12mm CCS (2)



12T Pinion Gear



6x12x4mm BB (2)



C1. Install differential housing onto front bulkhead

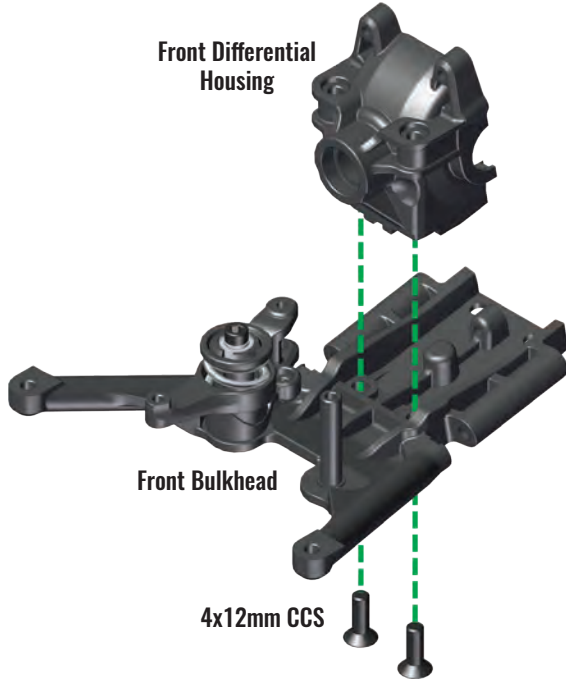

C2. Install 12T pinion gear into differential housing

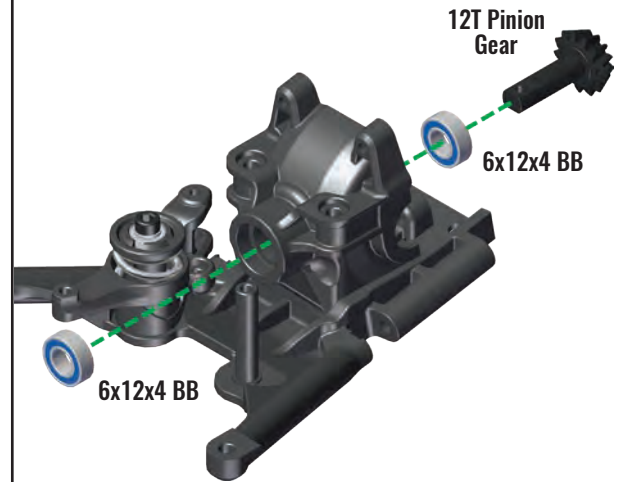

FRONT BULKHEAD BAG

Front Differential Cover

Front Shock Tower

3x10mm BCS (2)



3x15mm BCS (2)



C3. Install differential assembly



DIFFERENTIAL BAG

Black Lithium Grease

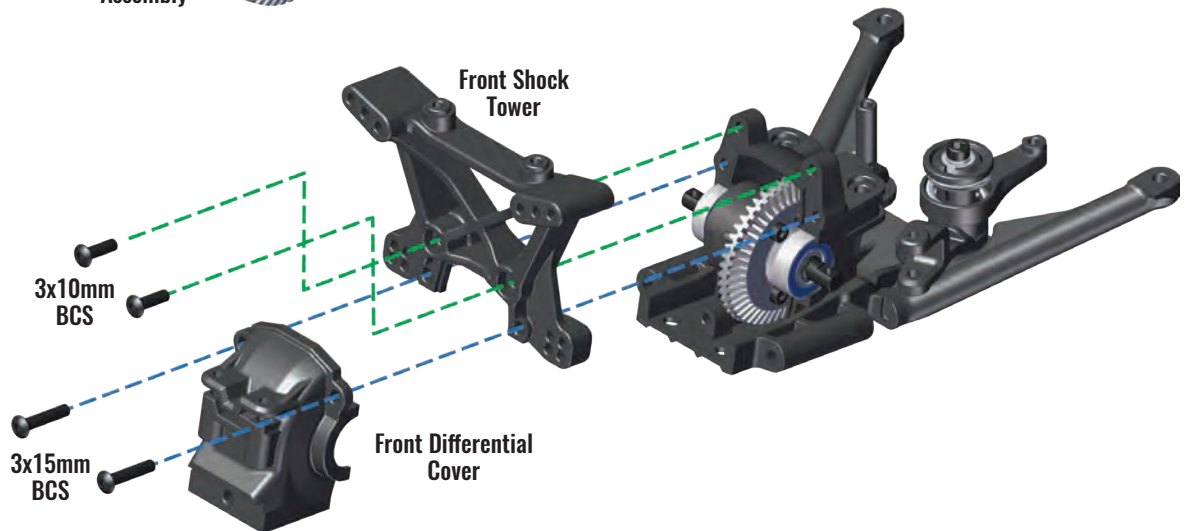

ACCESSORY

A Aluminum Accessory
6839X Shock Tower

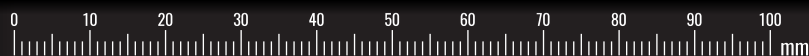

C. FRONT MODULE ASSEMBLY

FRONT BULKHEAD BAG

C4. Install front suspension arms

Front Suspension Arms (L&R)

Front Tie Bar

Front Suspension Pins (2)



3x15mm BCS



ACCESSORY



Aluminum Accessory
6823R Red Tie Bar

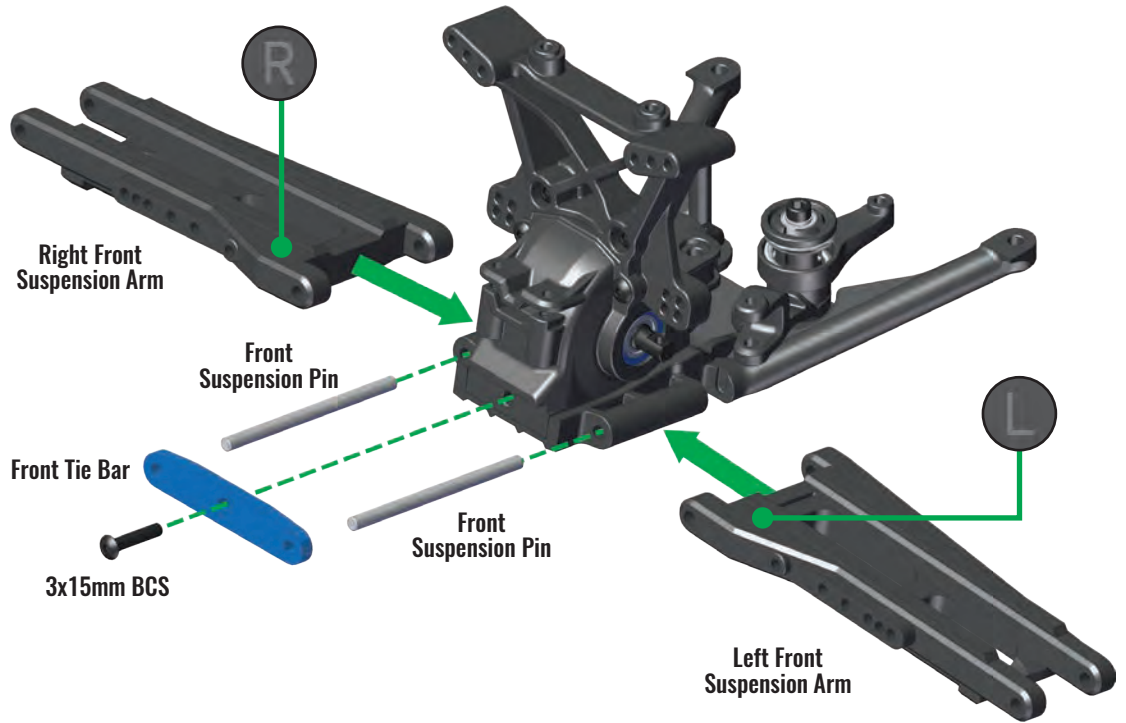

FRONT BULKHEAD BAG

C5. Install lower skidplate

Front Lower Skidplate

4x10mm CCS (3)

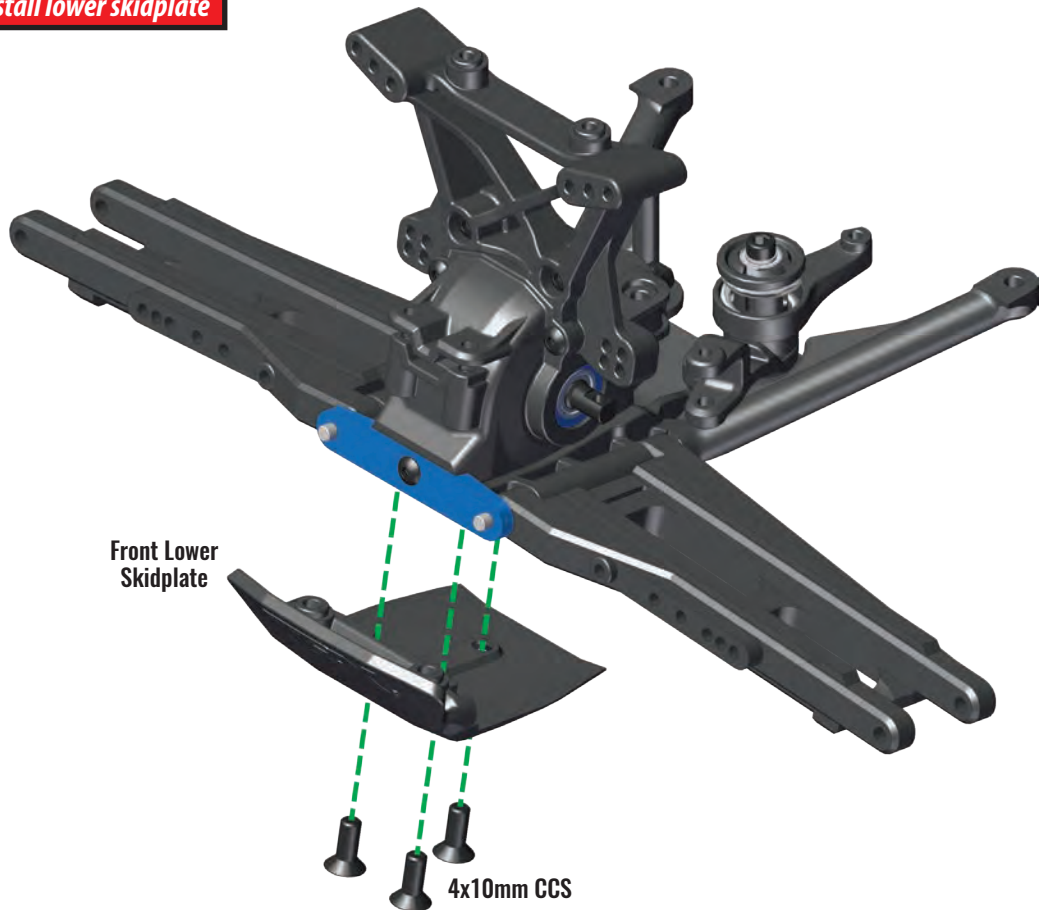

C. FRONT MODULE ASSEMBLY

FRONT BULKHEAD BAG

C6. Assemble front hubs

Steering Blocks (L&R)

Caster Blocks (L&R)

3x12mm CSS (4)



5x11x4mm BB (2)



10x15x4mm BB (2)



ACCESSORY

- A** Aluminum Accessory
 - 6832X Blue Caster Block
 - 6832R Red Caster Block
 - 6837X Blue Steering Block
 - 6837R Red Steering Block

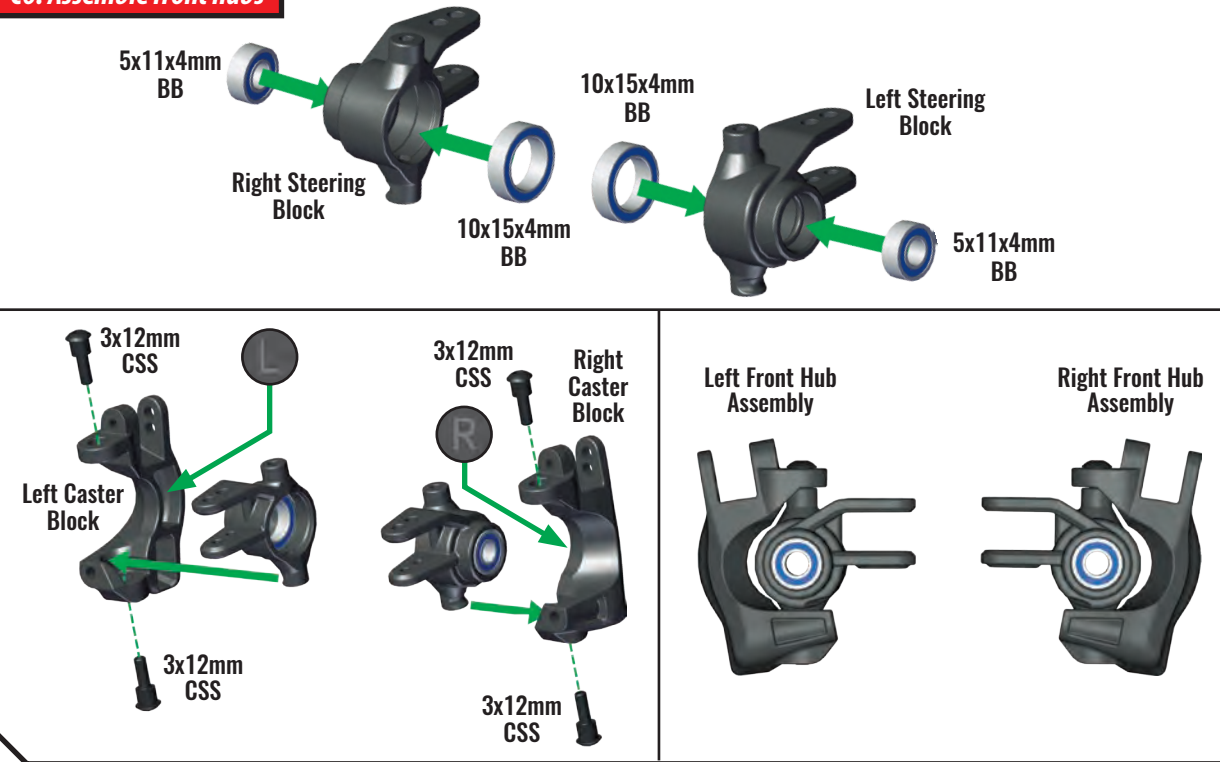

FRONT BULKHEAD BAG

C7. Install front driveshafts into hub assemblies

Outer Driveshaft

Inner Driveshaft

5x8x0.5 PTFE Washer



2x9.8mm Pin



Wheel Adapter

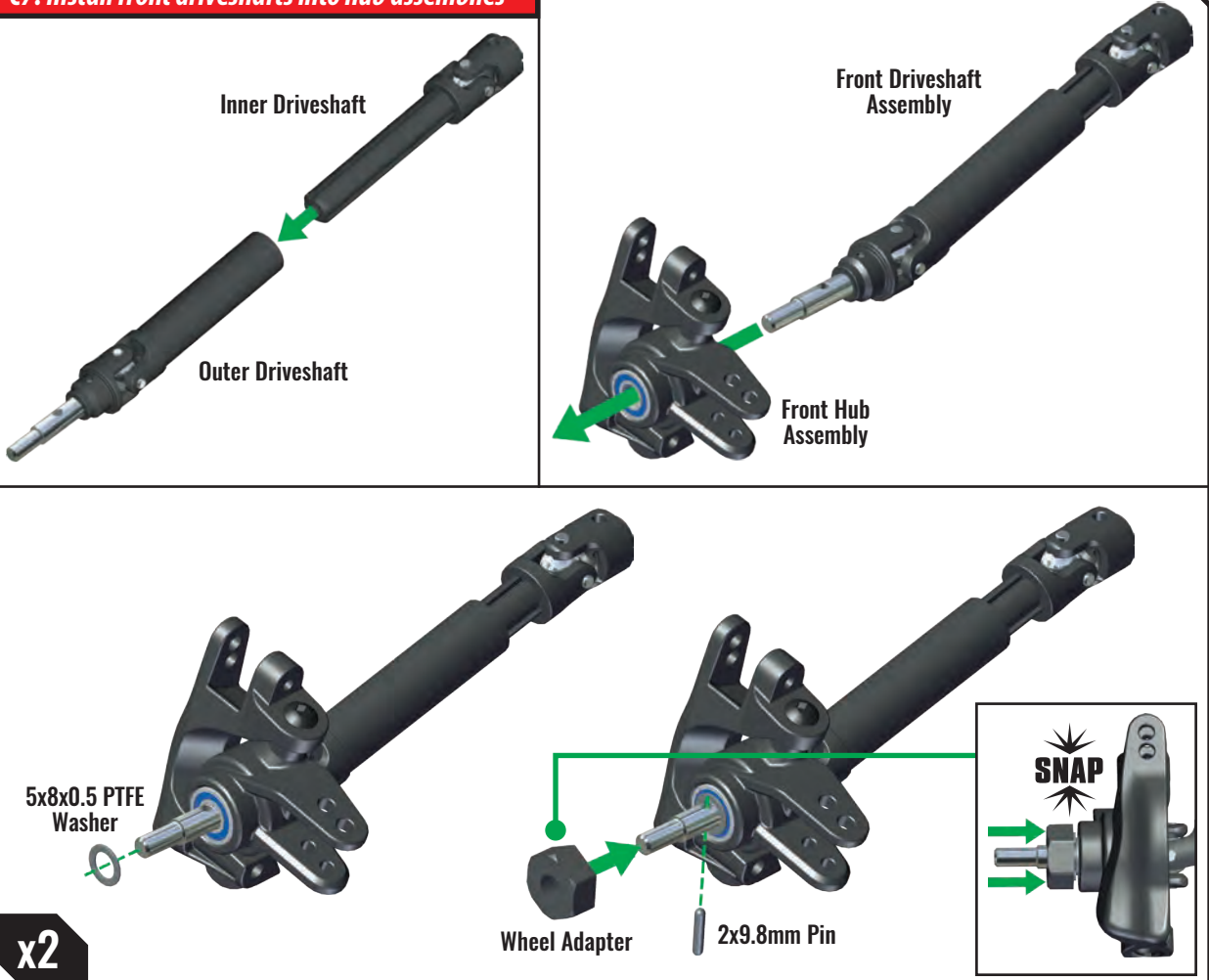

ACCESSORY

- A** Aluminum Accessory
 - 1654X Wheel Hubs
- O** Option Part
 - 6851R Constant-Velocity Driveshafts

x2



C. FRONT MODULE ASSEMBLY

FRONT BULKHEAD BAG

C8. Install front driveshaft and hub assemblies

3x11mm Screw Pin (2)



3x28mm Hinge Pin (2)



Left Front Assembly

3x11mm Screw Pin

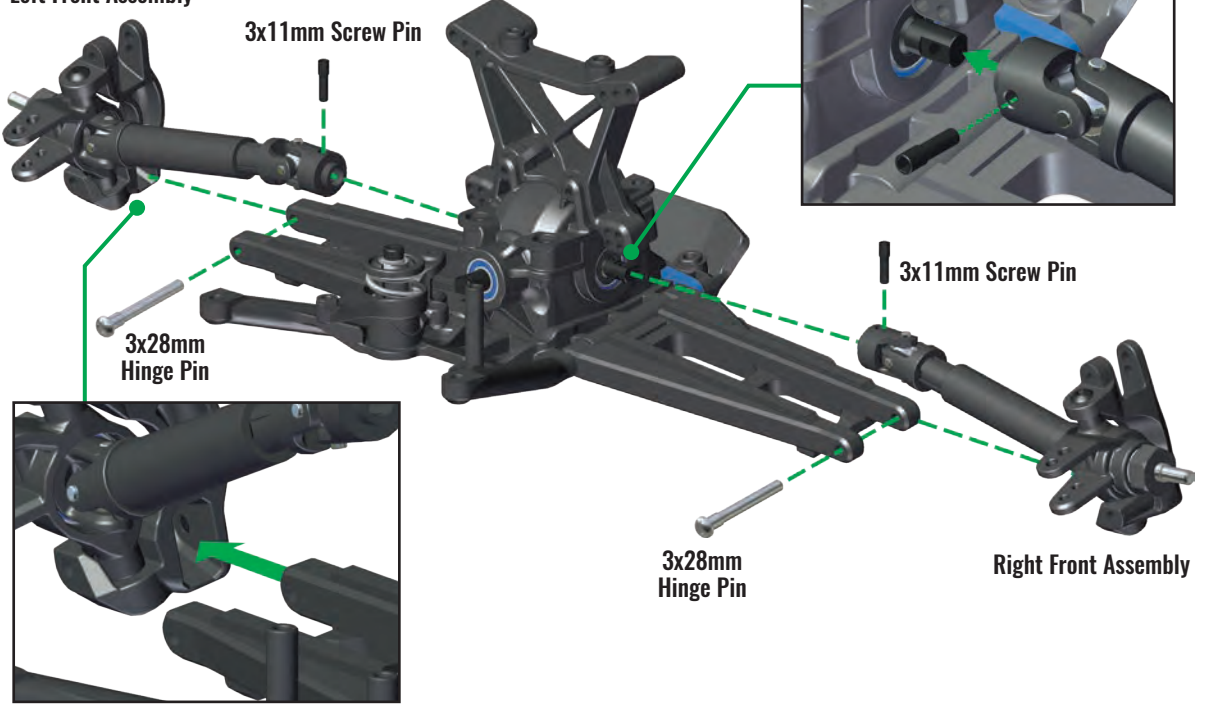

3x28mm Hinge Pin

3x11mm Screw Pin

3x28mm Hinge Pin

Right Front Assembly

FRONT BULKHEAD BAG

C9. Install front camber links

Camber Links (2)

3x12mm CSS (2)



3x15mm BCS (2)



6.25x8.5mm Bushing (2)



3x6x0.5mm MW (2)



Camber link outer mounting location

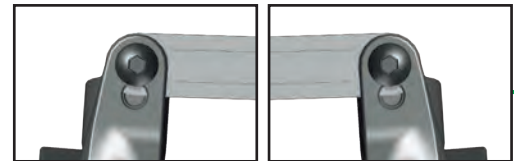

6.25x8.5mm Bushing

Camber Links

3x6x0.5mm MW

Camber Links

3x12mm CSS

6.25x8.5mm Bushing

3x15mm BCS

Camber link inner mounting location

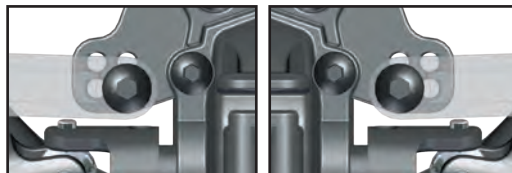

3x15mm BCS

ACCESSORY

- Option Part 5539 Turnbuckle Camber Links

C. FRONT MODULE ASSEMBLY

FRONT BULKHEAD BAG

C10. Install front bumper

Front Bumper

4x14mm BCS (2)



3x15mm BCS (2)

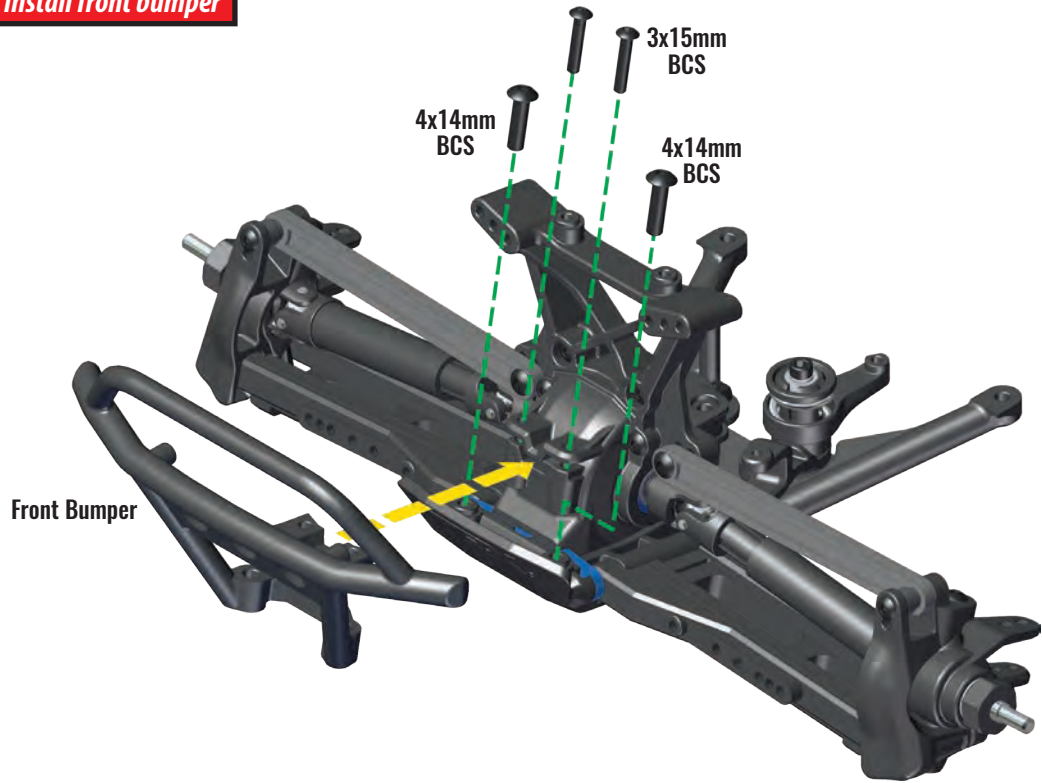

Front Bumper

FRONT BULKHEAD BAG

C11. Install assembled front shocks

Front Shock Guards

3x12mm CSS (2)



3x18mm BCS (4)



3x6x0.5mm MW (2)



Shock Guard Spacer (2)



Lower shock mounting location



Upper shock mounting location

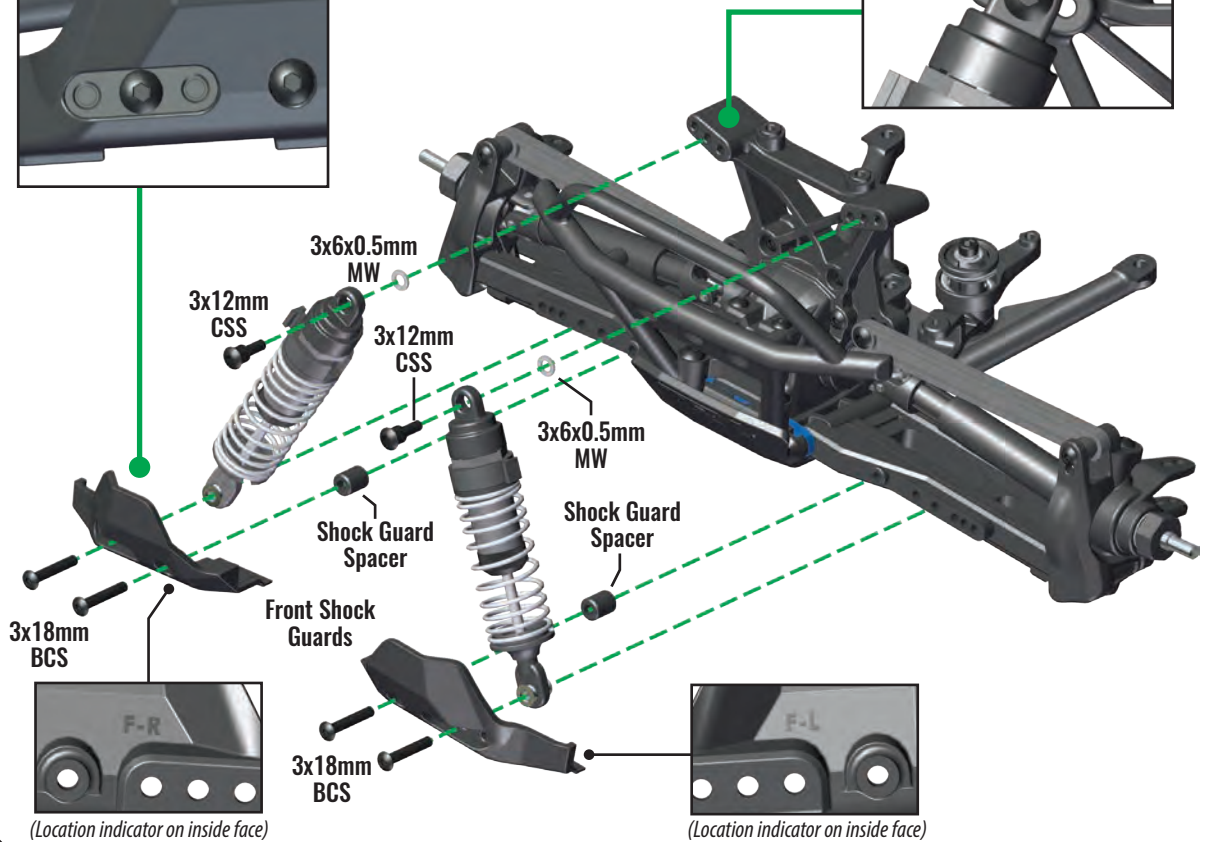

3x18mm BCS



(Location indicator on inside face)

Front Shock Guards

3x18mm BCS



(Location indicator on inside face)

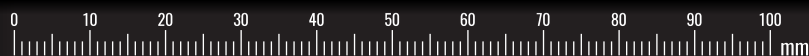

C. FRONT MODULE ASSEMBLY

STEERING BAG

- Bellcrank Sleeve
- Bellcrank Arm
- 3x8mm CS
- 3x6x.05mm MW
- 5x8x2.5mm PB (2)
- 3x10mm CSS (2)

C12. Assemble bellcrank onto chassis

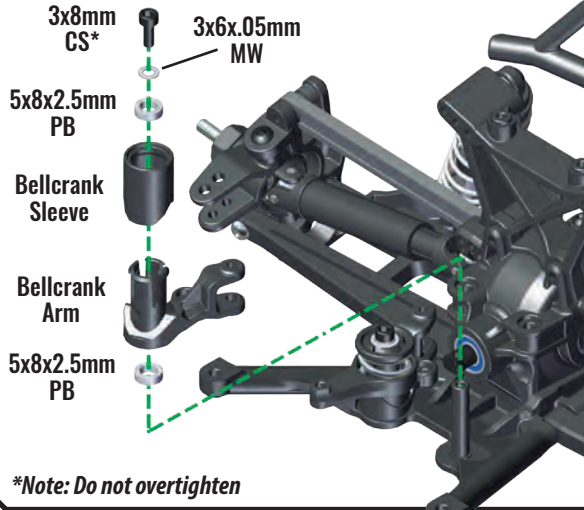

*Note: Do not overtighten

C13. Install steering draglink onto bellcrank

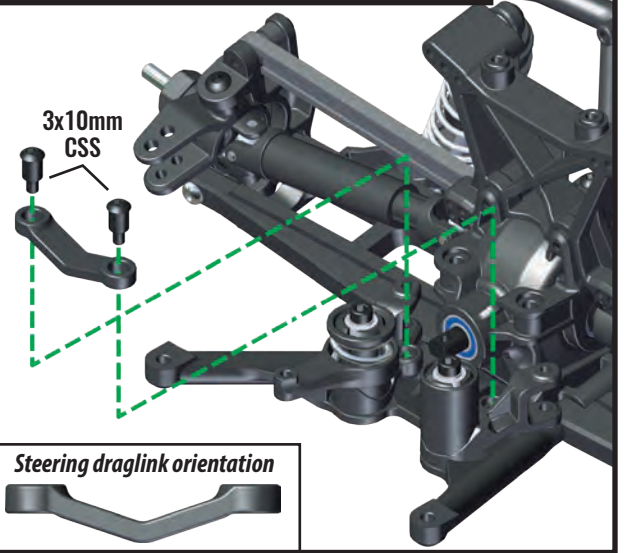

STEERING BAG

- Toe Link (2)
- 3x15mm CCS (2)
- 3x15mm BCS (2)

C14. Install toe links

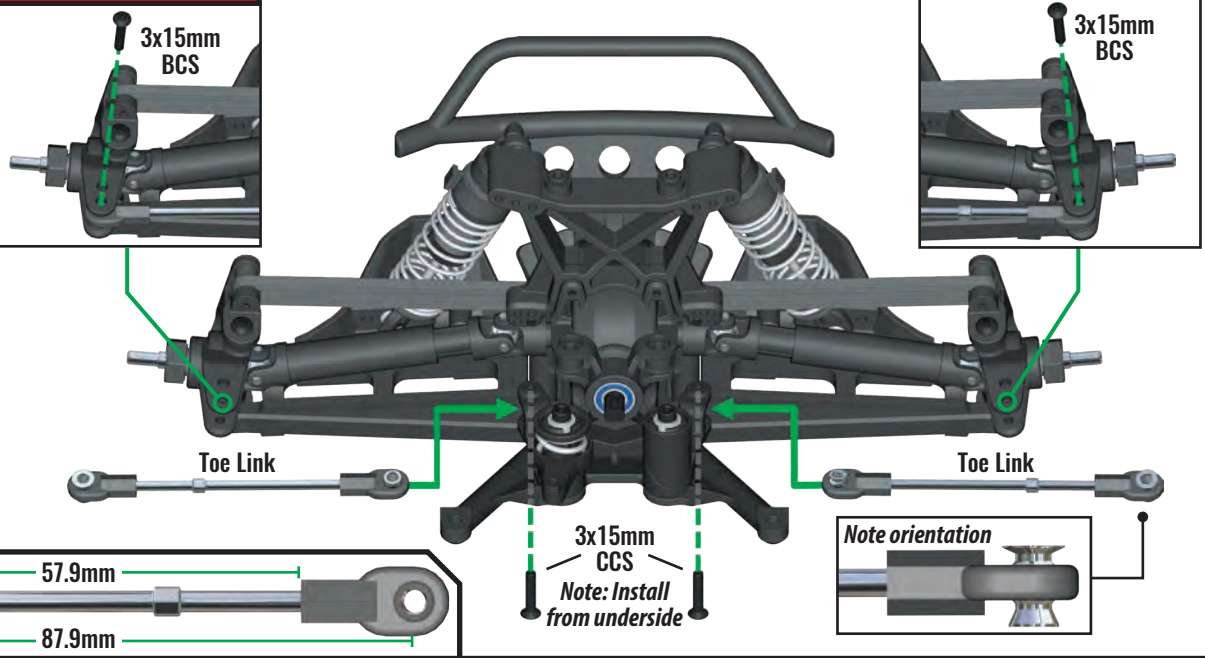

ACCESSORY

- Option Part 3643 Turnbuckle Camber Links

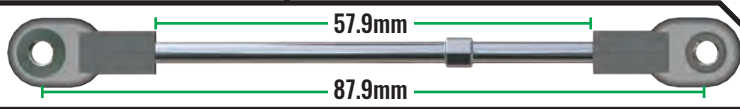

Completed front module assembly

Check your assembly carefully.

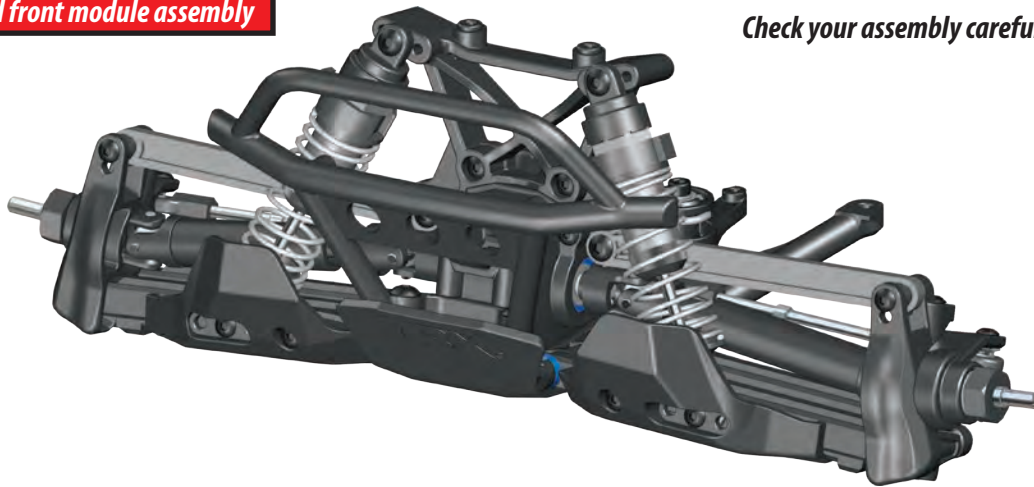

D. REAR MODULE ASSEMBLY

REAR BULKHEAD BAG

Rear Differential Housing

Rear Bulkhead

3x10mm CCS (2)



12T Pinion Gear



12x18x4mm BB

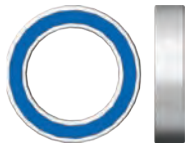

DIFFERENTIAL BAG

Black Lithium Grease

D1. Install differential housing onto rear bulkhead

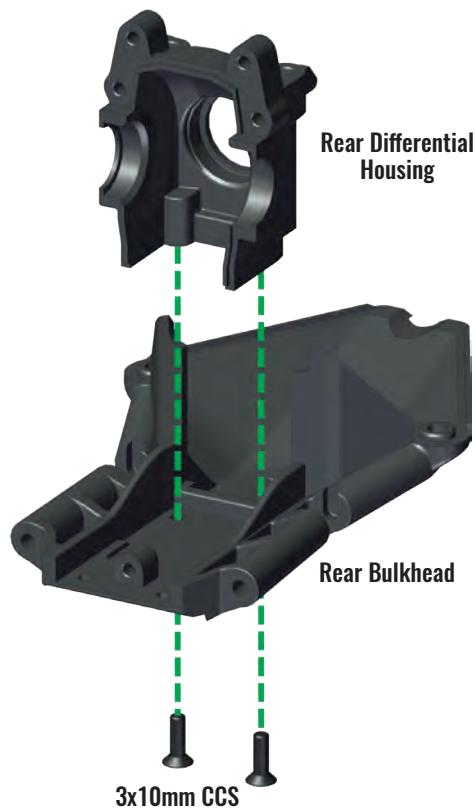

D2. Install 12T pinion gear into differential housing

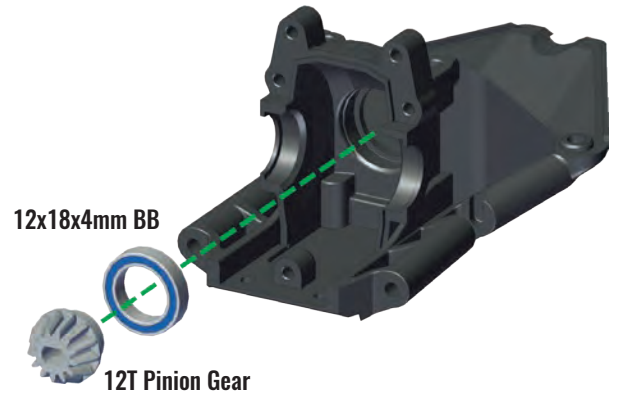

D3. Install differential into differential housing

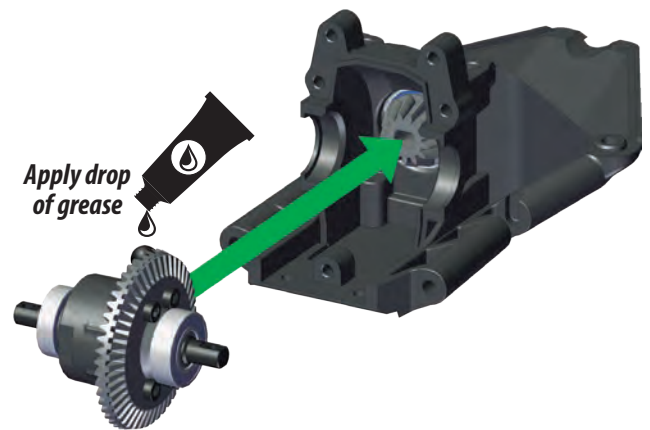

REAR BULKHEAD BAG

Rear Differential Cover

Rear Shock Tower

3x12mm BCS (2)



3x15mm BCS (2)



D4. Install rear shock tower and differential cover

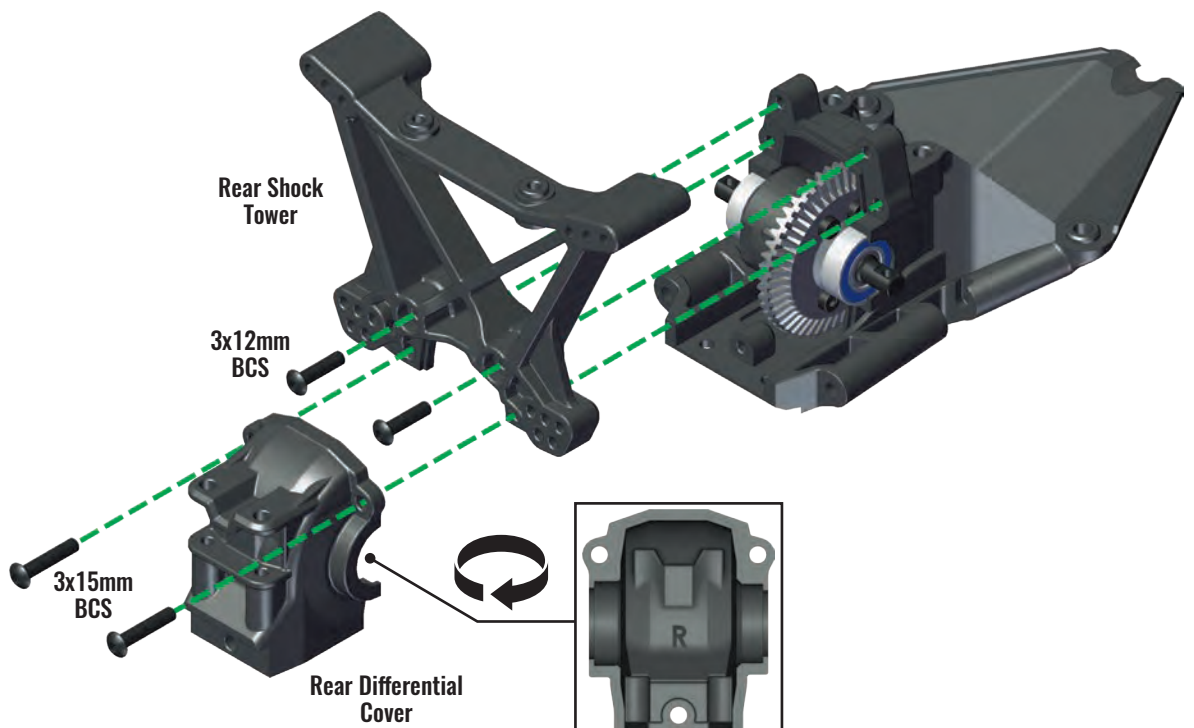

ACCESSORY

 Aluminum Accessory
6838X Shock Tower



D. REAR MODULE ASSEMBLY

REAR BULKHEAD BAG

D5. Install suspension arms onto rear bulkhead assembly

Rear Suspension Arms (L&R)

Rear Suspension Pins (2)

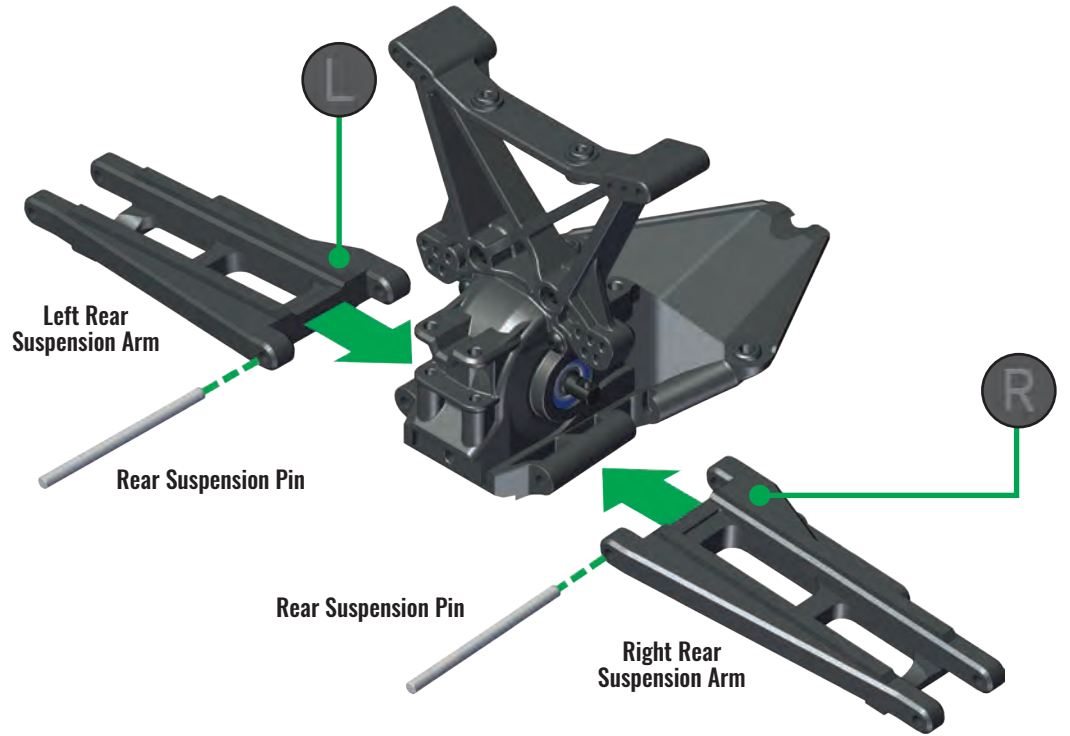

REAR BULKHEAD BAG

D6. Assemble and install rear bumper

Upper Wheelie Bar Mount

Lower Wheelie Bar Mount

Rear Skid Plate

Rear Tie Bar

3x12mm CCS (2)



3x15mm BCS (4)



3x20mm BCS (3)

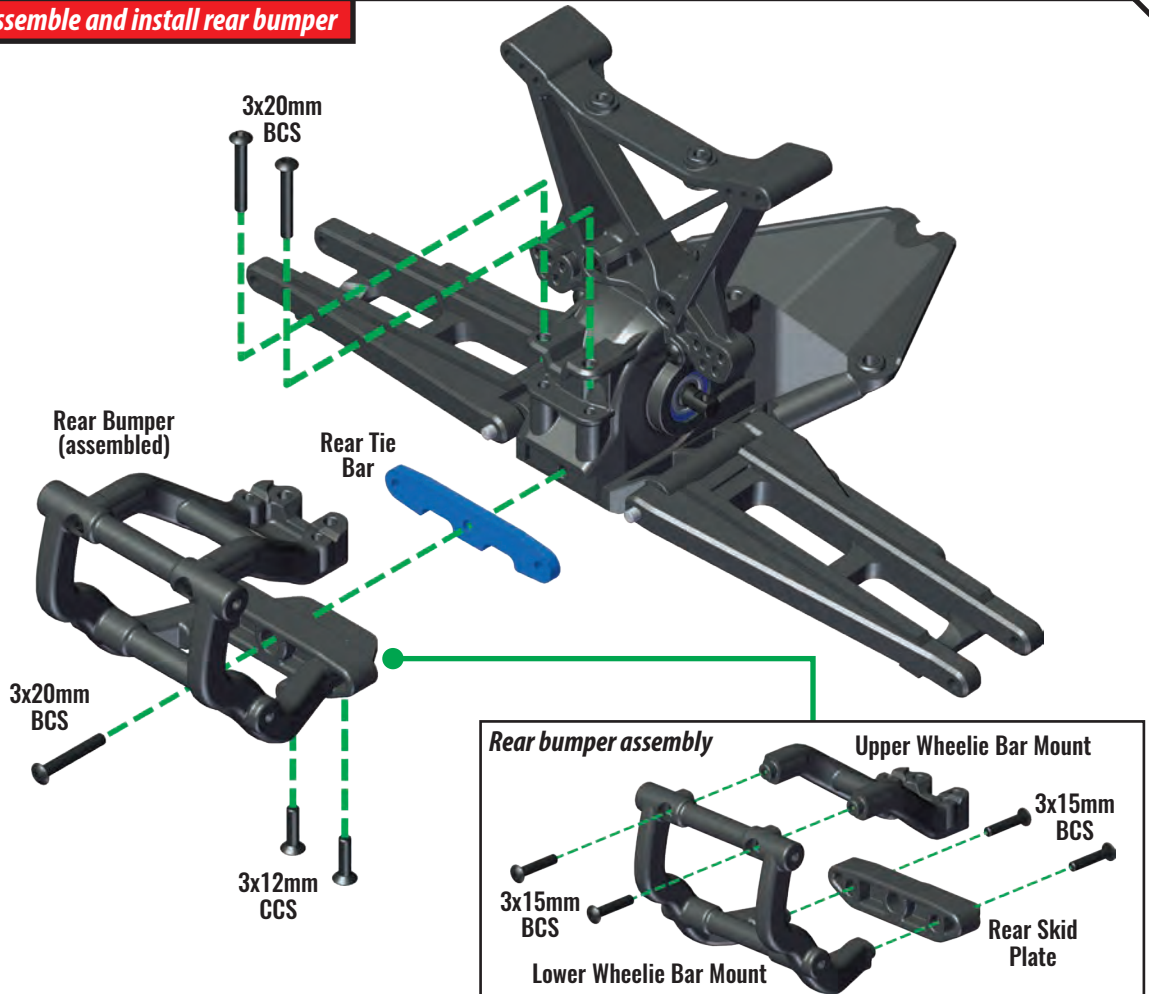

D. REAR MODULE ASSEMBLY

REAR BULKHEAD BAG

D7. Assemble rear driveshafts and hub assemblies

Outer Driveshaft

Inner Driveshaft

Stub Axle Carrier

5x11x4mm BB (2)



5x8x0.5 PTFE Washer (2)



2x9.8mm Pin



Wheel Adapter



ACCESSORY

A Aluminum Accessory
Stub Axle Carrier
1952X - Blue
1952A - Red

A Aluminum Accessory
1654X Wheel Hubs

O Option Part
6852R Constant-Velocity Driveshafts

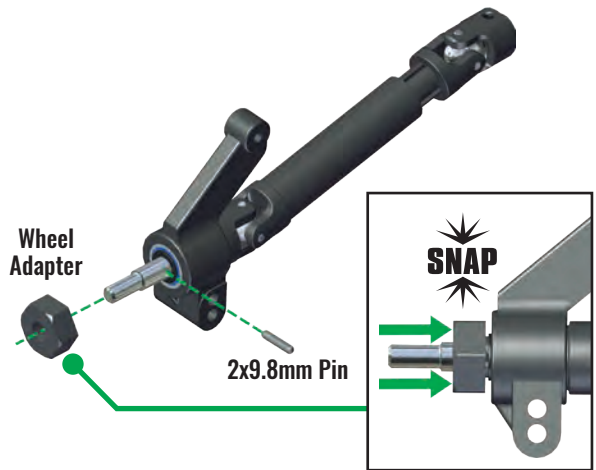
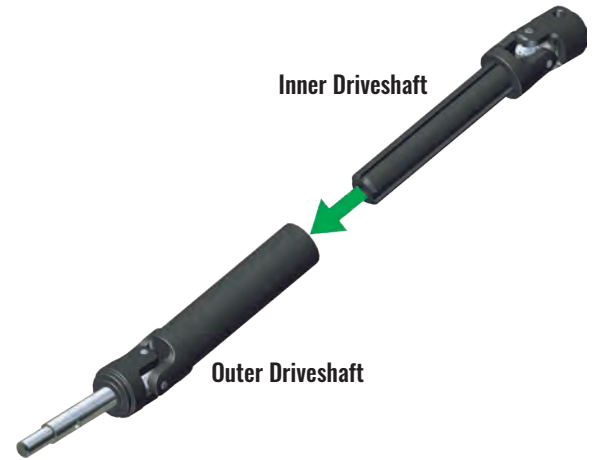
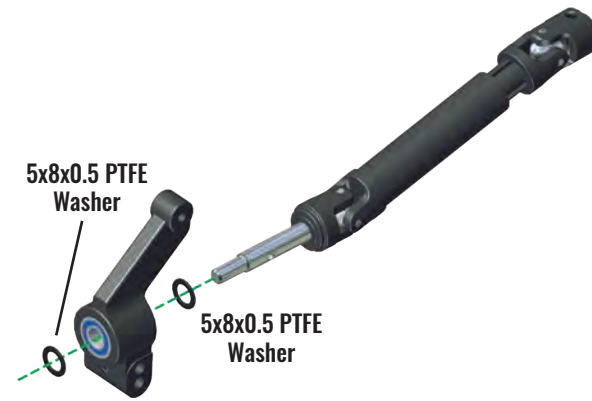
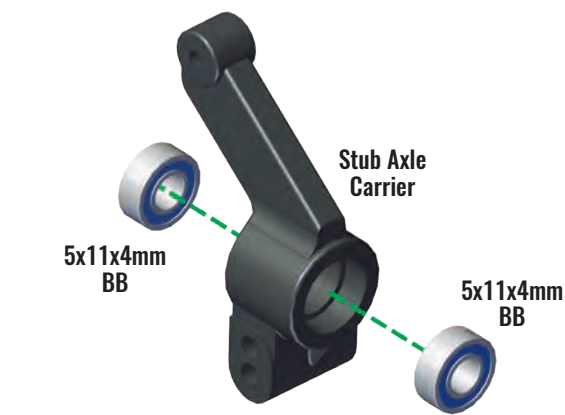

FRONT BULKHEAD BAG

D8. Install rear driveshaft and hub assemblies

3x11mm Screw Pin (2)



3x28mm Hinge Pin (2)

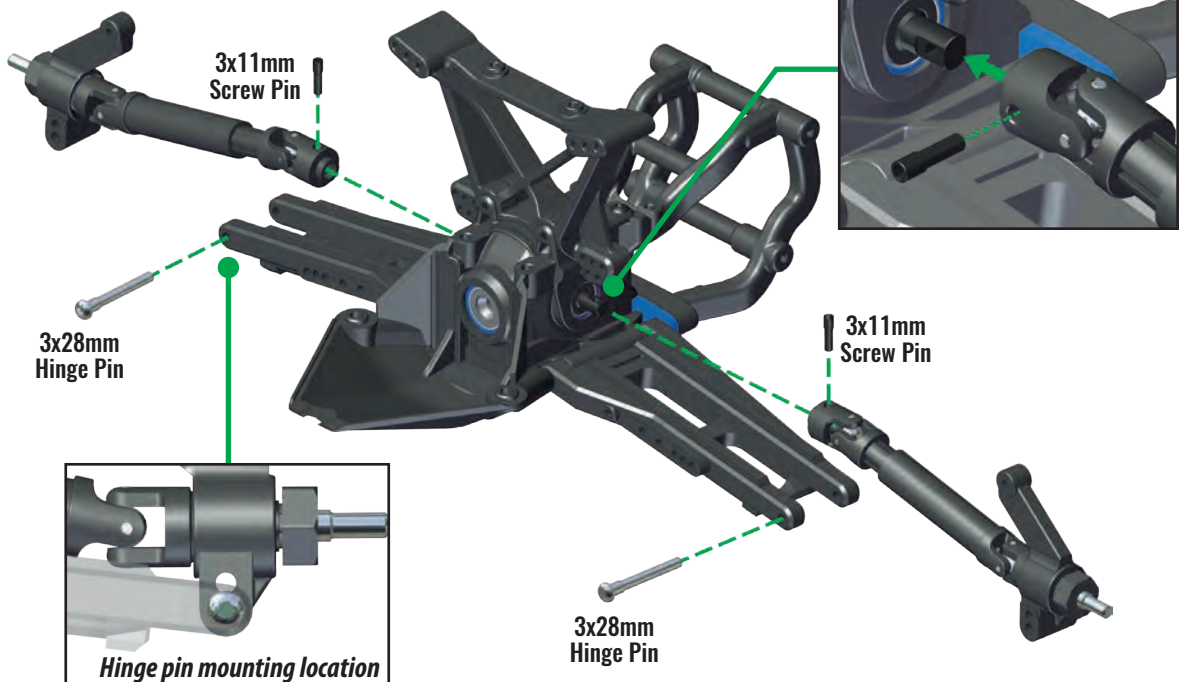

D. REAR MODULE ASSEMBLY

REAR BULKHEAD BAG

D9. Install rear camber links

Camber Links (2)

3x12mm CSS (4)



3x6x0.5mm MW (4)

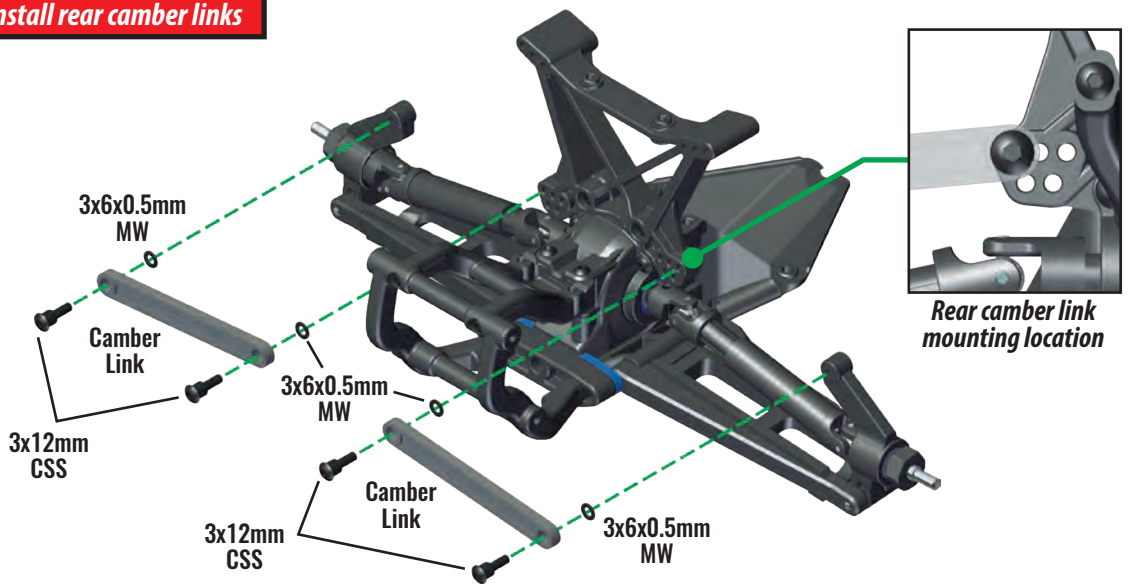

ACCESSORY

0 Option Part
3644 Turnbuckle
Camber Links

REAR BULKHEAD BAG

D10. Install assembled rear shocks

Rear Shock Guards

3x12mm CSS (2)



3x6x0.5mm MW (2)



3x18mm BCS (4)



Shock Guard Spacer (2)

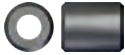

Upper shock mounting location



Lower shock mounting location

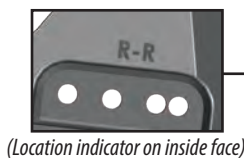

(Location indicator on inside face)

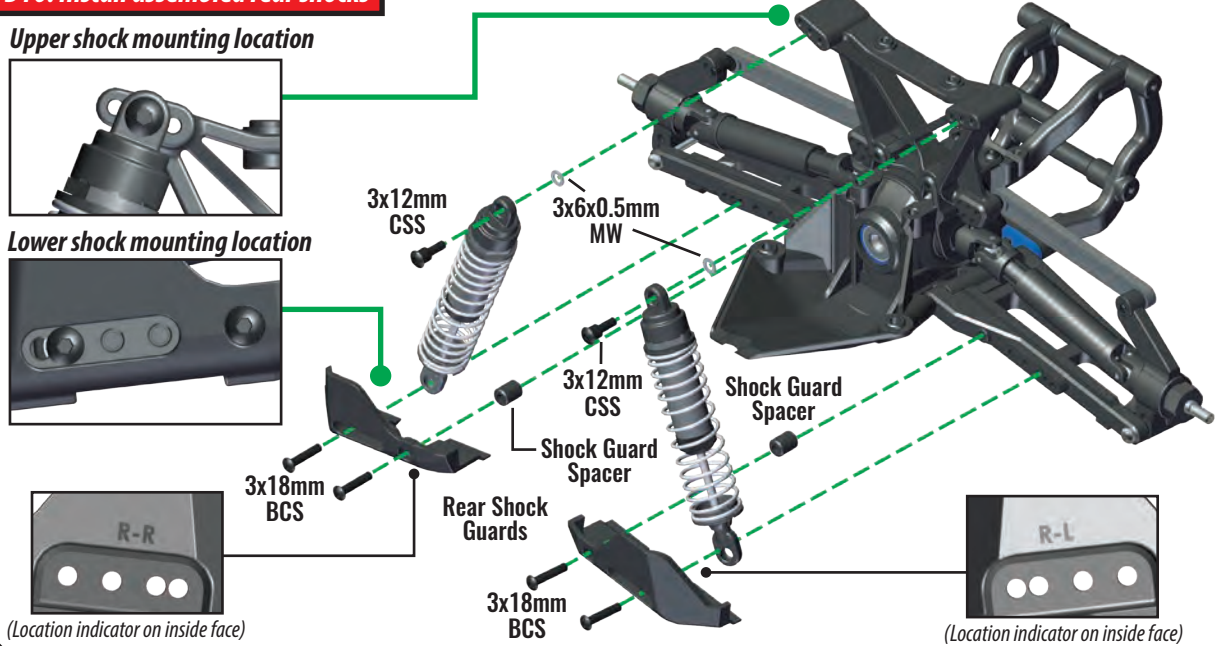

(Location indicator on inside face)

Completed rear module assembly

Check your assembly carefully.

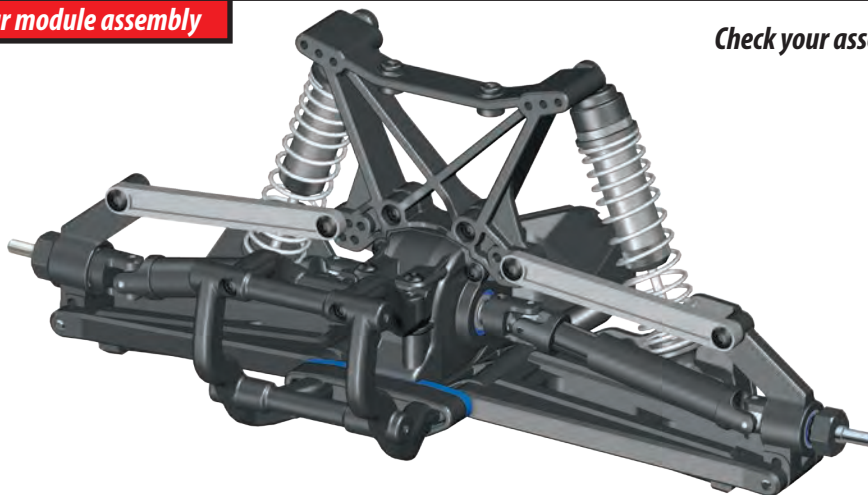

E. CHASSIS ASSEMBLY

CHASSIS BAG

- Motor Mount
- Telemetry Magnet Holder Cover
- 3x6mm CCS
- M3x0.5 NL
- 3x6mm FCS
- 3x10mm BCS (2)
- 3x8mm BCS

E1. Assemble motor mount and install into chassis

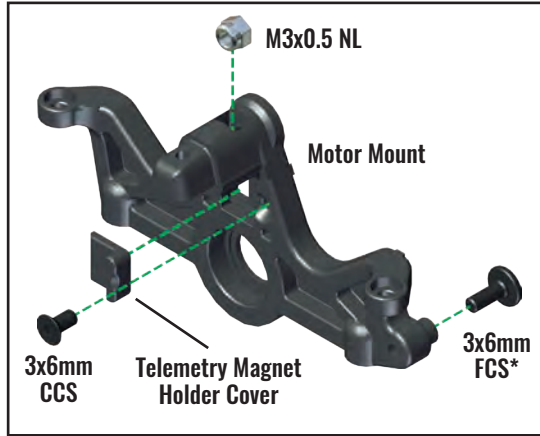

**Note: Do not overtighten*

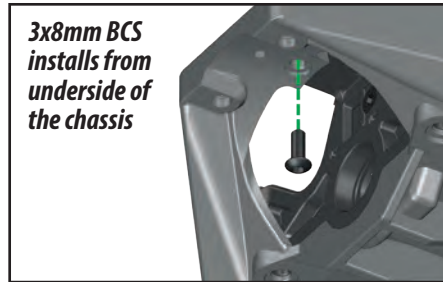

3x8mm BCS installs from underside of the chassis

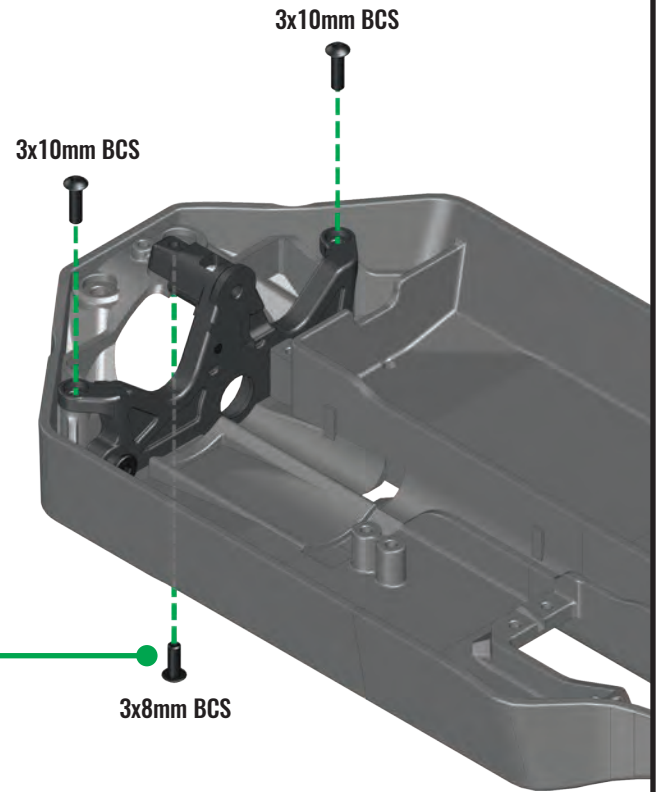

CHASSIS BAG

- 3x6mm FCS (3)



Servo (sold separately)

E2. Install servo into chassis

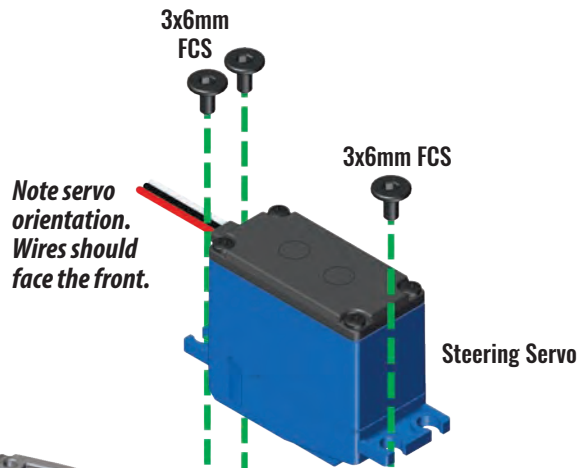

Note servo orientation. Wires should face the front.

ACCESSORY

- Option Part 2056 High-Torque Servo
- 2075 Digital High-Torque Servo
- 2275R Digital High-Speed Servo
- 2250 Coreless Servo
- 2255 Brushless Servo

Steering servo sold separately



E. CHASSIS ASSEMBLY

CHASSIS BAG

3x15mm BCS



3x15mm CCS



3x6mm BCS



Battery Post



Center Driveshaft Cover

Battery Hold Down Retainer

Battery Hold Down

Angled Body Clip

E3. Install battery hold down

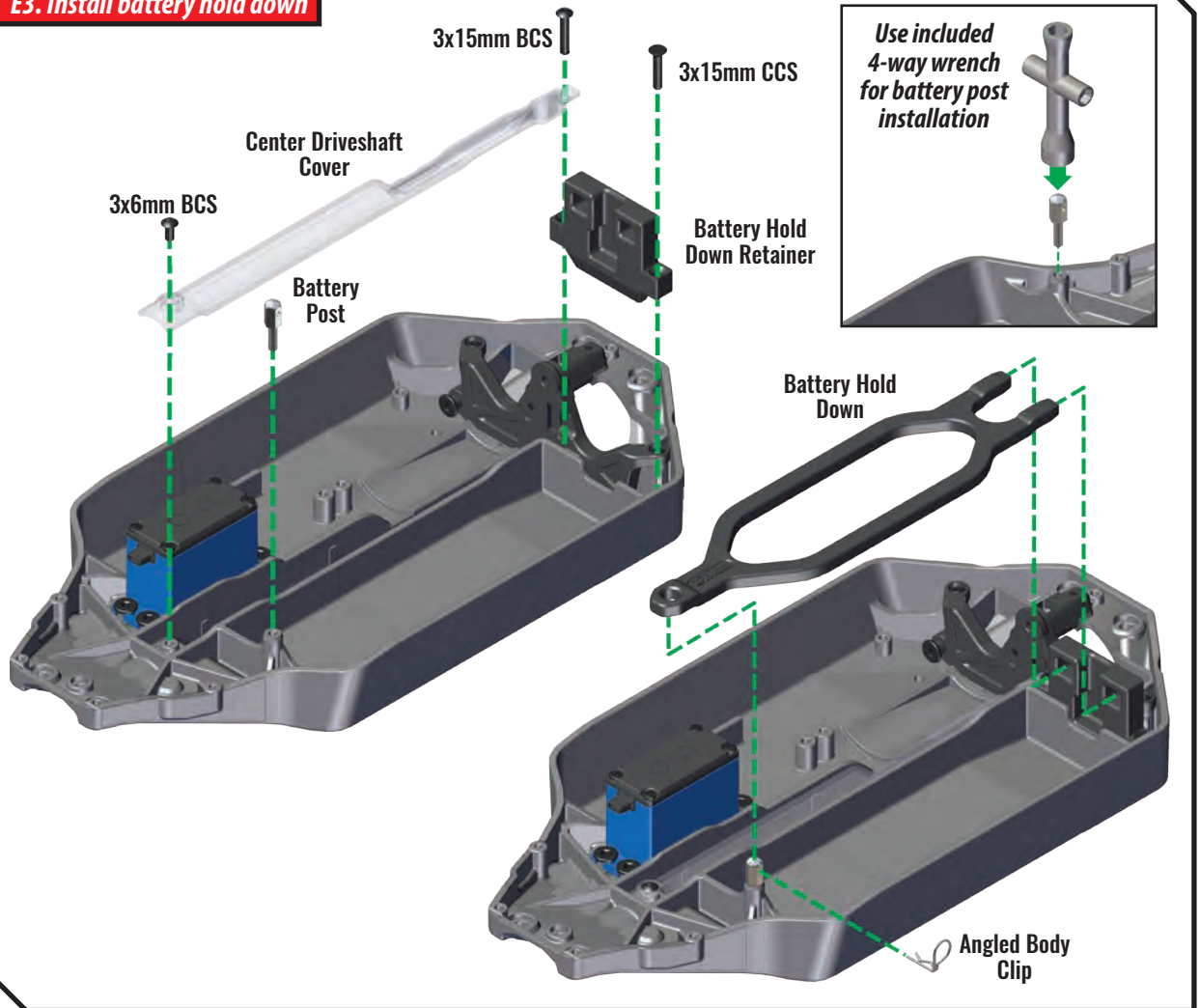

CHASSIS BAG

3x15mm BCS (2)



Electronic Speed Control
(sold separately)

ACCESSORY

Option Part 3018R XL-5
Electronic Speed Control

Option Part 3355R VXL-3s
Electronic Speed Control

E4. Install electronic speed control into chassis

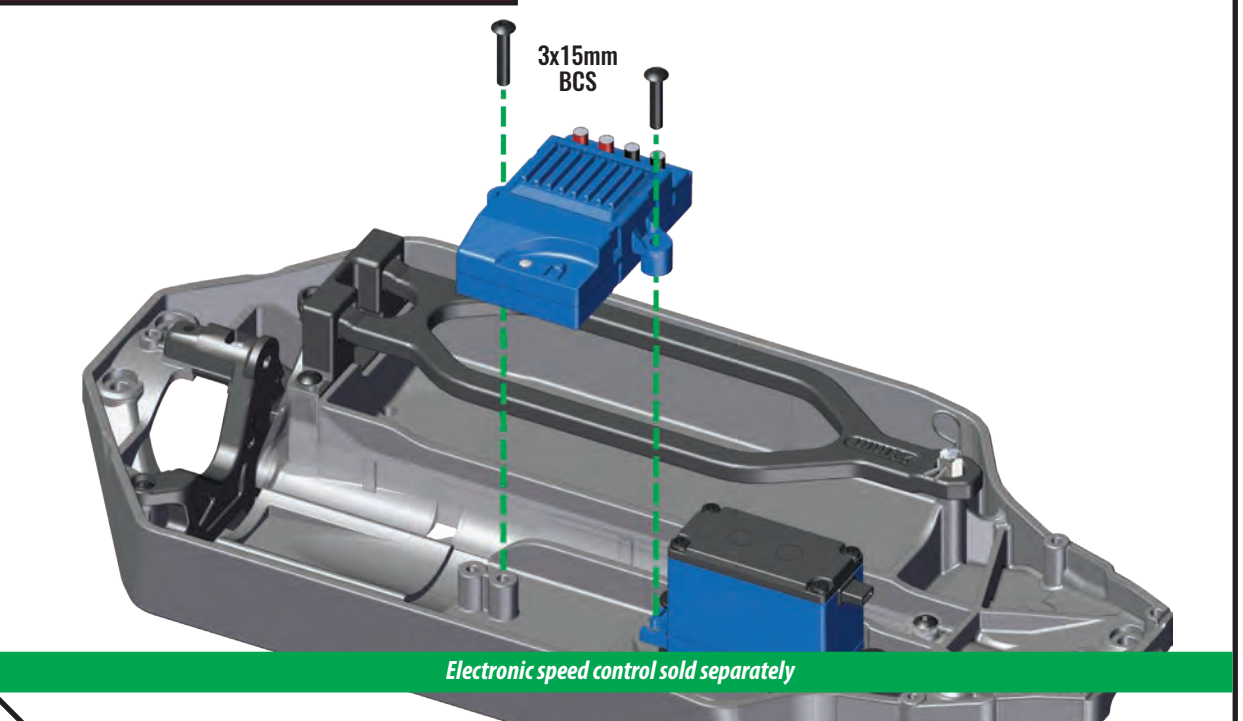

CHASSIS BAG

- Lower Receiver Box
- 2.5x8mm CS (2)
- Receiver Foam Tape

Receiver (sold separately)
Receiver box dimensions:
54.5mm x 29mm x 19mm

ACCESSORY

- Option Part**
6519 TQi 2.4GHz
3Ch Micro Receiver
- Option Part**
6533 TQi 2.4GHz
5Ch Micro Receiver

E5. Install lower receiver box onto chassis

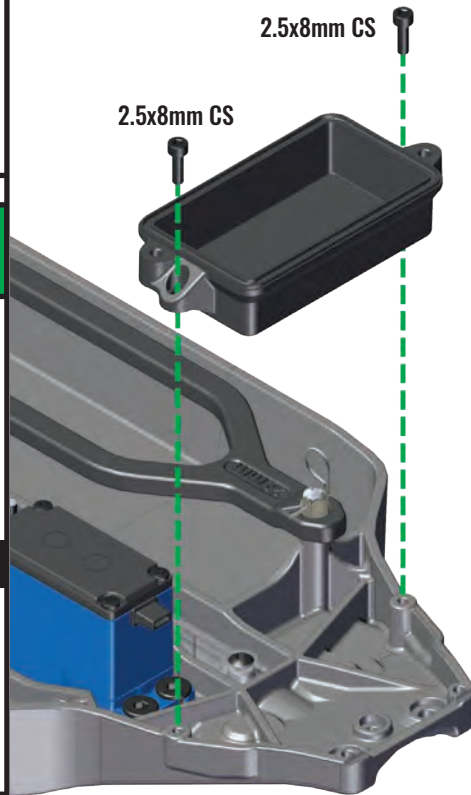

E6. Install receiver into lower receiver box

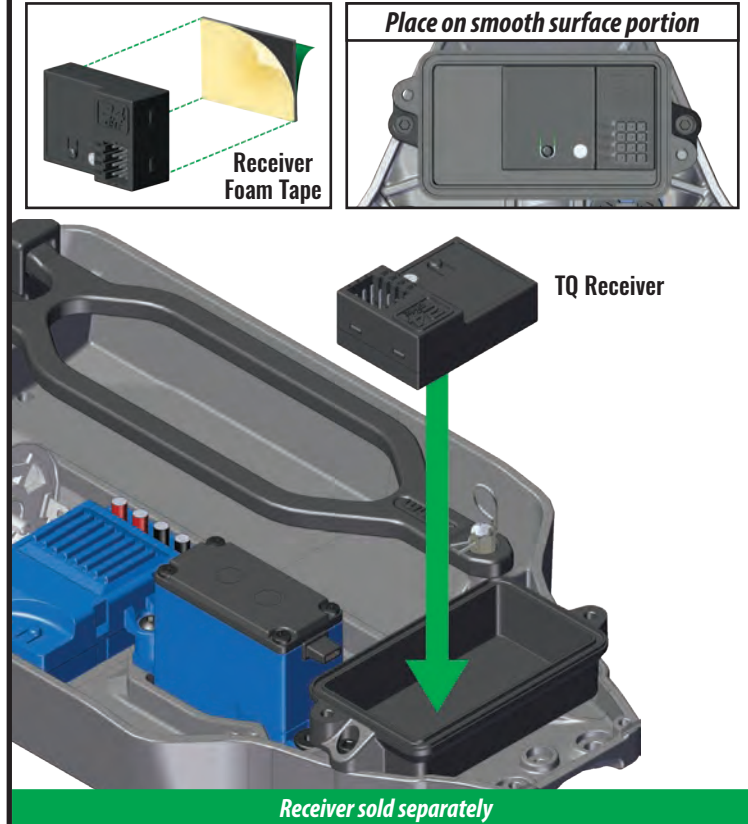

CHASSIS BAG

- Lower Receiver Box Foam
- Receiver Box Cover

E7. Install wires into receiver box

1 Install lower foam into receiver box cover

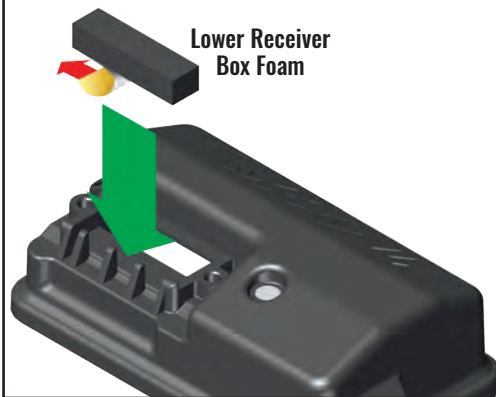

3 Bundle excess wires in receiver box

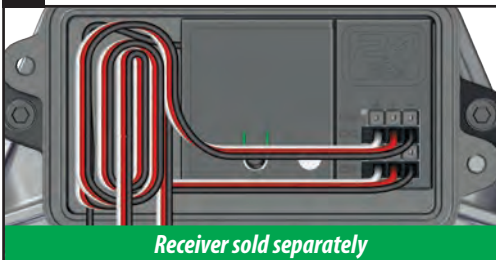

2 Route wires through receiver box cover

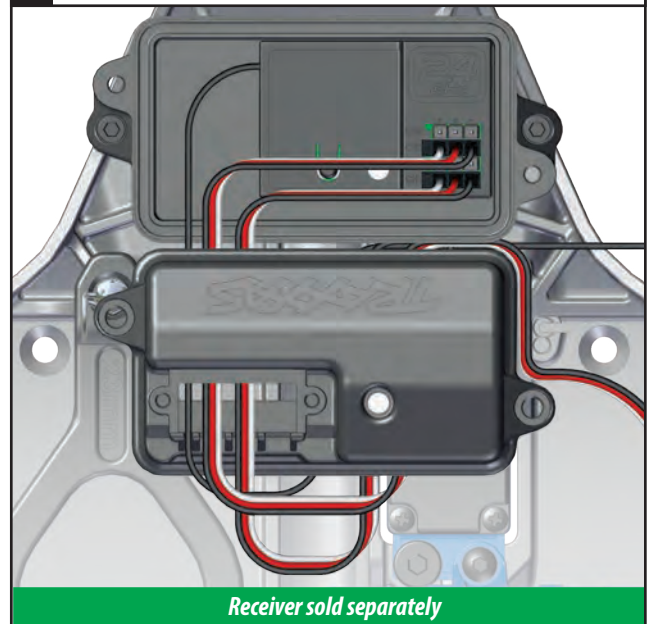

Traxxas Radio Systems:
CH1 - Steering Servo
CH2 - Electronic Speed Control

E. CHASSIS ASSEMBLY

CHASSIS BAG

Antenna Tube

Antenna Cap

3x4mm GS

3x10mm CS (2)

O-Ring Seal

Upper Receiver Box Foam

Receiver Wire Clamp

2.5x8mm CS (2)

ELECTRONICS BAG

Silicone Grease

E8. Slide the antenna wire into the antenna tube and insert tube into chassis

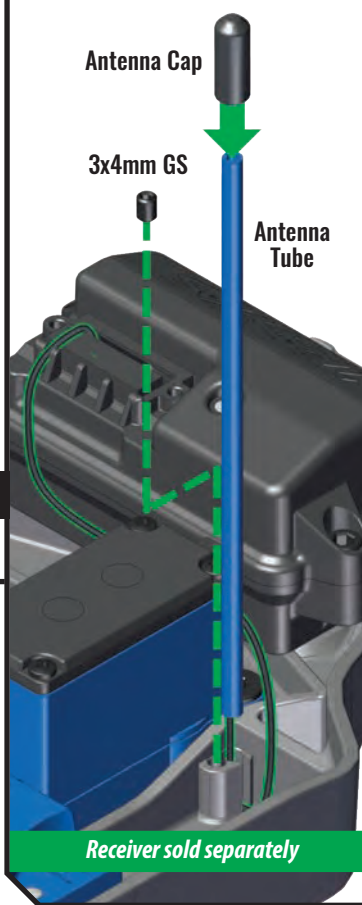

E9. Waterproof and seal the receiver box

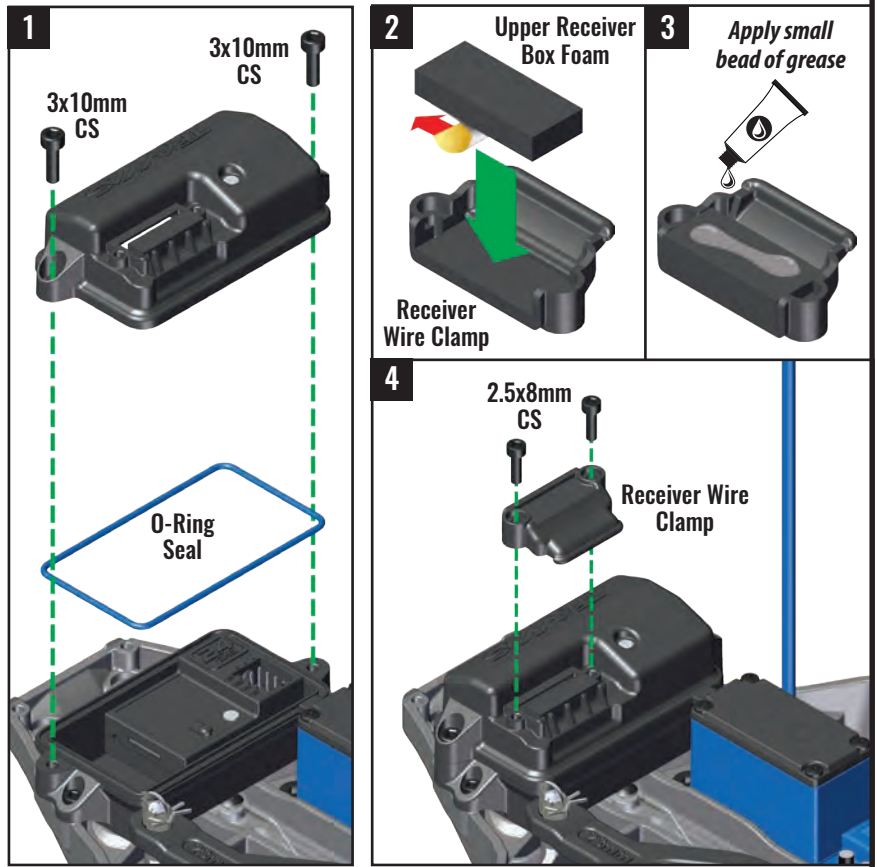

To prevent loss of radio range, do not kink or cut the black wire, do not bend or cut the metal tip, and do not bend or cut the white wire at the end of the metal tip.

Completed chassis assembly

Check your assembly carefully.



F. SUSPENSION & DRIVELINE INSTALLATION

CENTER DRIVELINE BAG

F4. Install center driveshaft

Center Driveshaft

3x11 Screw Pin

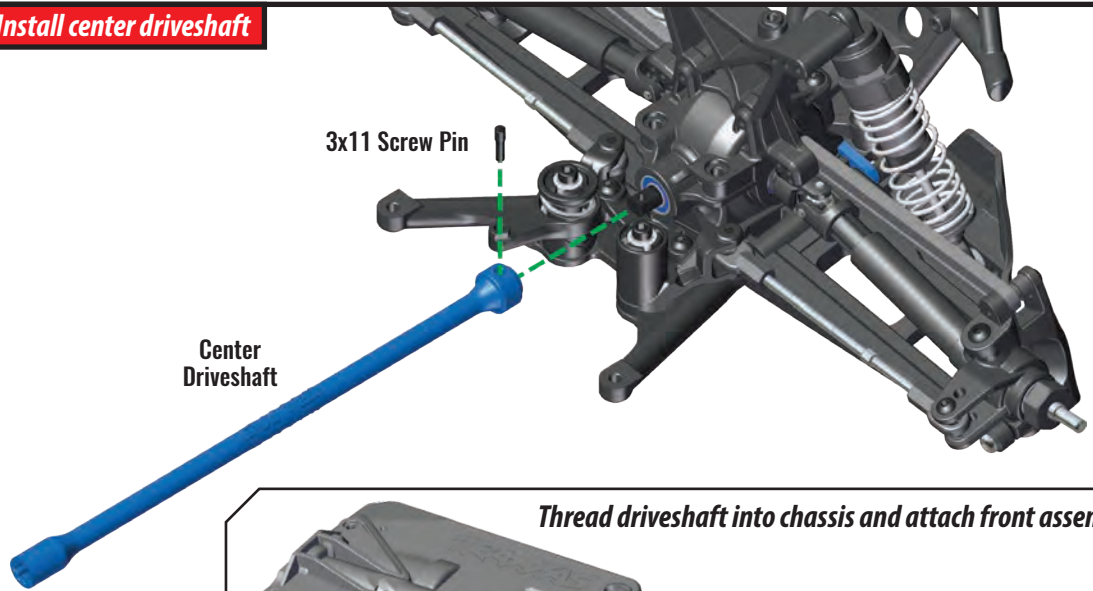

Center Driveshaft

3x11 Screw Pin

Thread driveshaft into chassis and attach front assembly

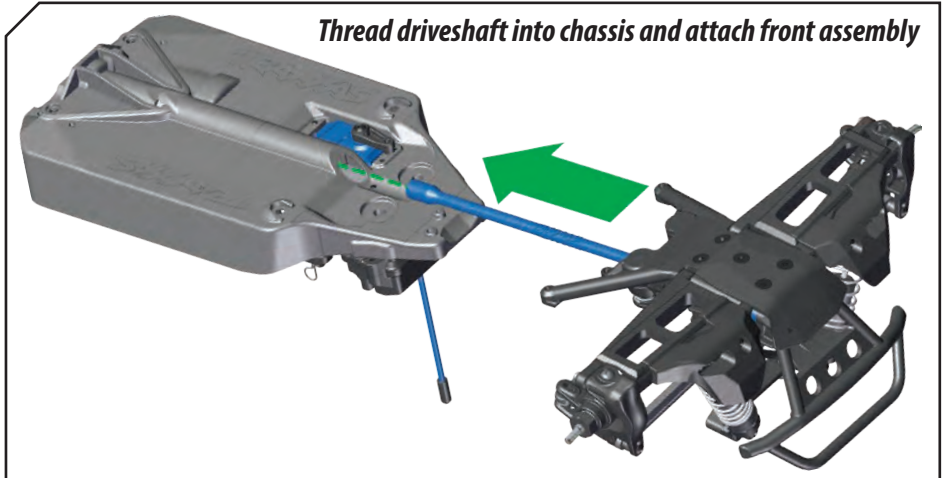

ACCESSORY

- Aluminum Accessory
- 6755 Aluminum Center Driveshaft

CHASSIS BAG

4x12mm BCS (2)



4x10mm CCS (2)



3x15mm BCS (2)



STEERING BAG

Steering Link

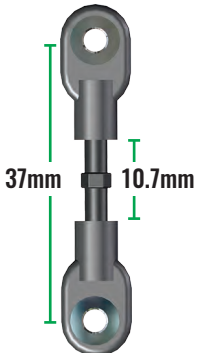

F5. Secure front assembly to chassis

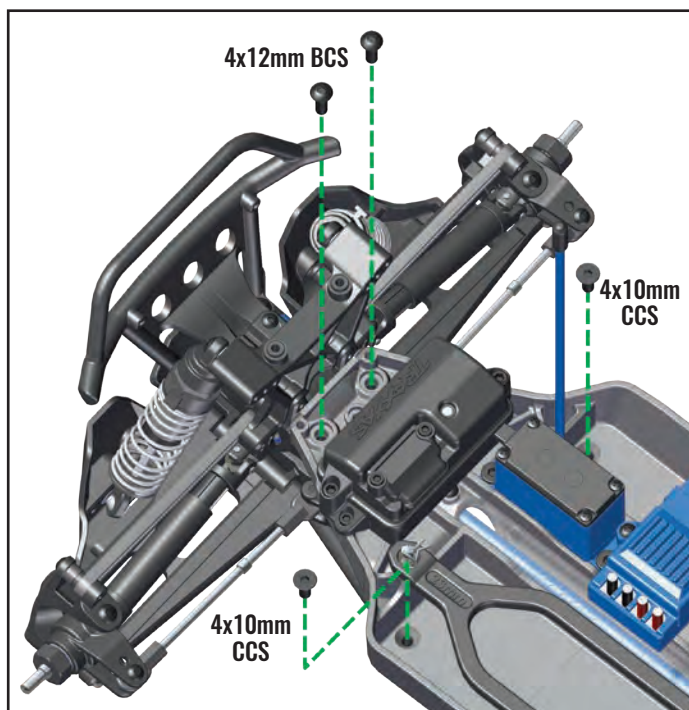

Note orientation

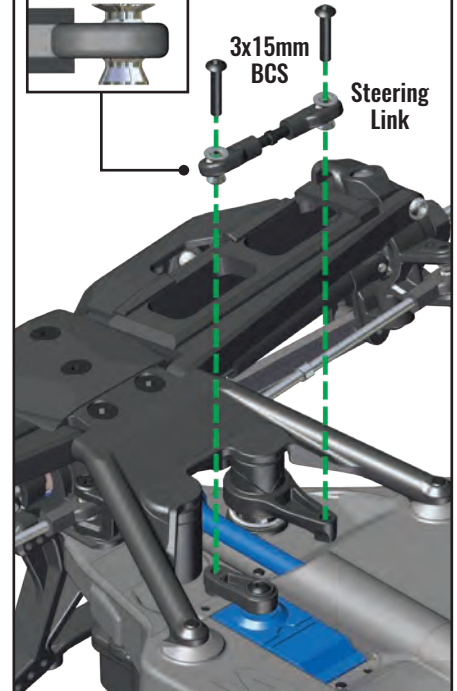

CHASSIS BAG

4x12mm BCS (4)



F6. Install rear assembly to chassis

Install slipper clutch assembly into chassis

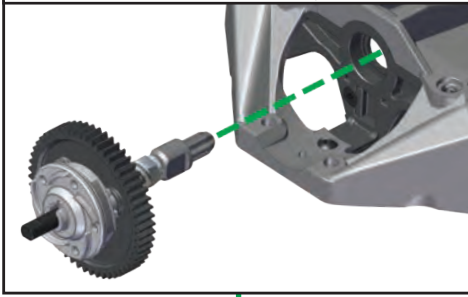

Note: Slipper clutch drive hub seats into center driveshaft

Install rear module onto chassis

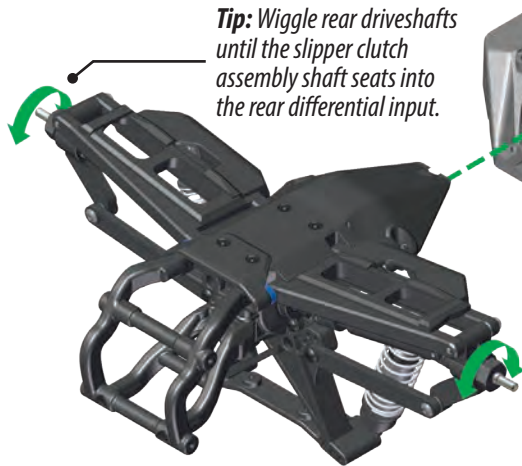

Tip: Wiggle rear driveshafts until the slipper clutch assembly shaft seats into the rear differential input.

Note: Make sure the rear bulkhead is mated to the chassis properly as shown before tightening screws.

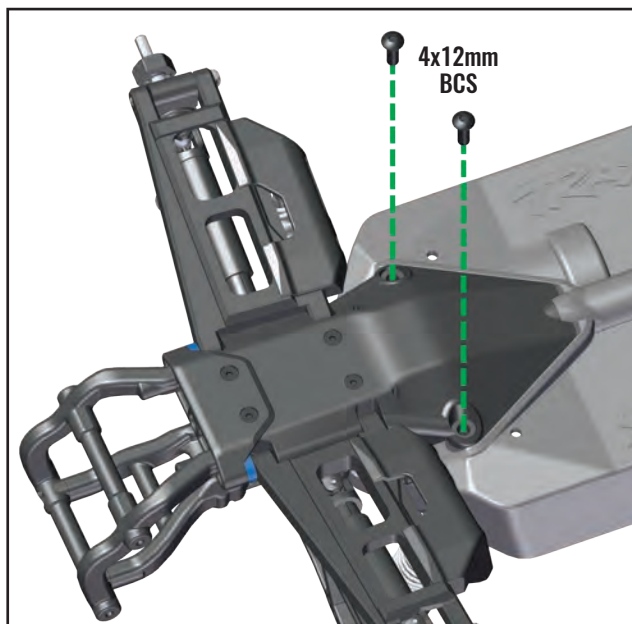

4x12mm BCS

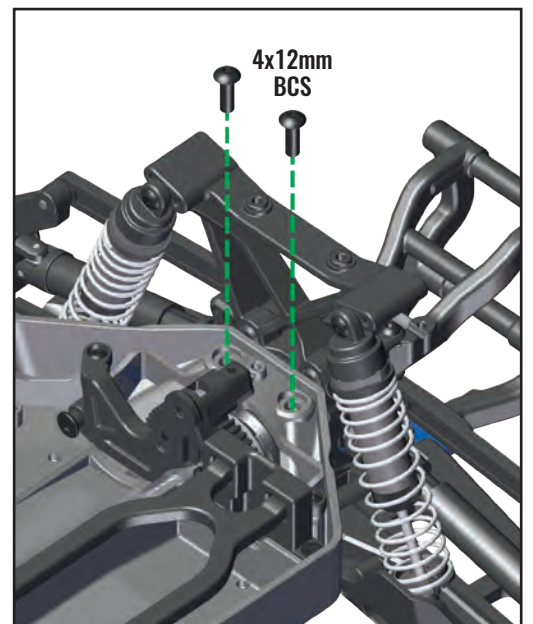

4x12mm BCS

F. SUSPENSION & DRIVELINE INSTALLATION

CHASSIS BAG

3x8mm CCS (2)



9-Tooth Pinion Gear



3x4 GS



3x15mm CS



Motor Plate

Wire Hold Down Clip

3x6mm BCS



F7. Install motor plate to motor

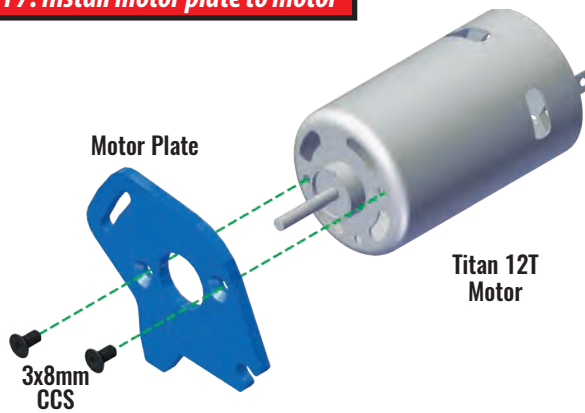

Motor sold separately

F8. Install 9T pinion onto motor



Motor sold separately

F9. Install motor into motor chassis

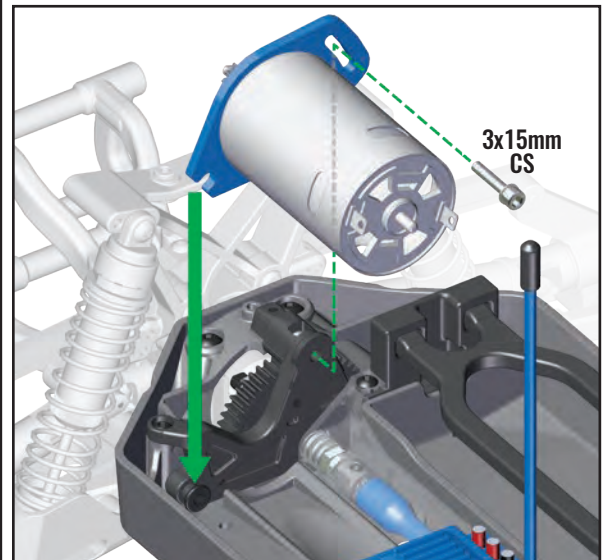

Plug bullet connectors from motor into ESC

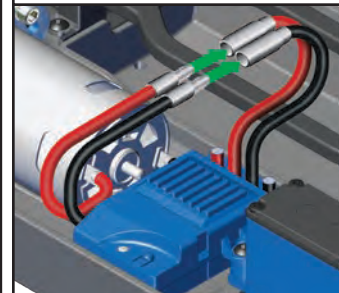

3x6mm BCS



Motor (sold separately)

ACCESSORY

O Option Part
3785 Titan 12T Motor

O Option Part
3351R Velineon Motor

A Aluminum Accessory
6890X 6061-T6
Aluminum Motor Plate

CHASSIS BAG

Gear Cover

3x6mm BCS



F10. Set gear mesh and install gear cover

Loosen the motor screw.
Cut a narrow strip of notebook
paper and run it into the gear mesh.

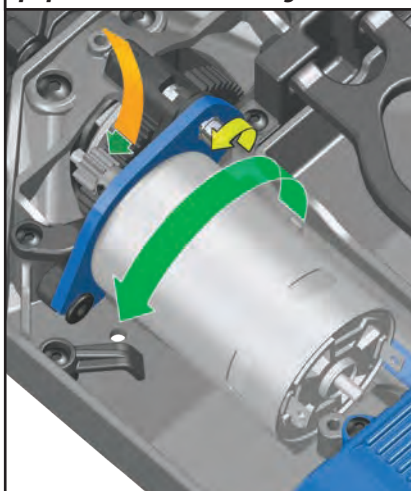

Slide the motor and pinion gear into
the spur gear. Retighten the motor
screws, and then remove the paper.

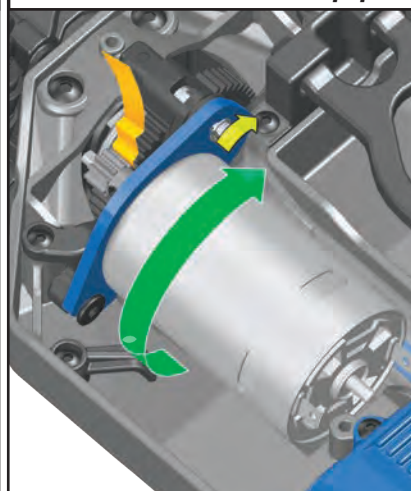

3x6mm BCS

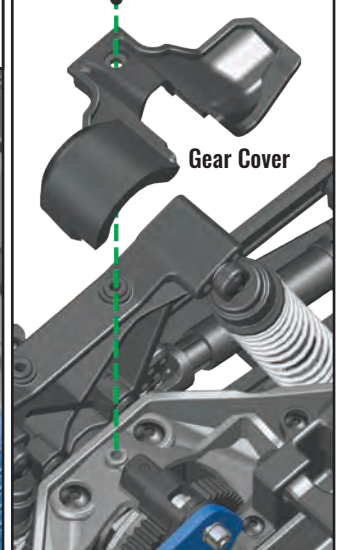

ACCESSORY

O Option Part
6877A Clear Gear Cover

G. FINAL ASSEMBLY

BODY MOUNT BAG

- Body Mount Post (4)
- Front Body Mount
- Rear Body Mount
- Post Foam Pad (2 Thin & 2 Thick)
- 3x8mm BCS (4)
- 3x10mm BCS (4)

G1. Install front and rear body mounts

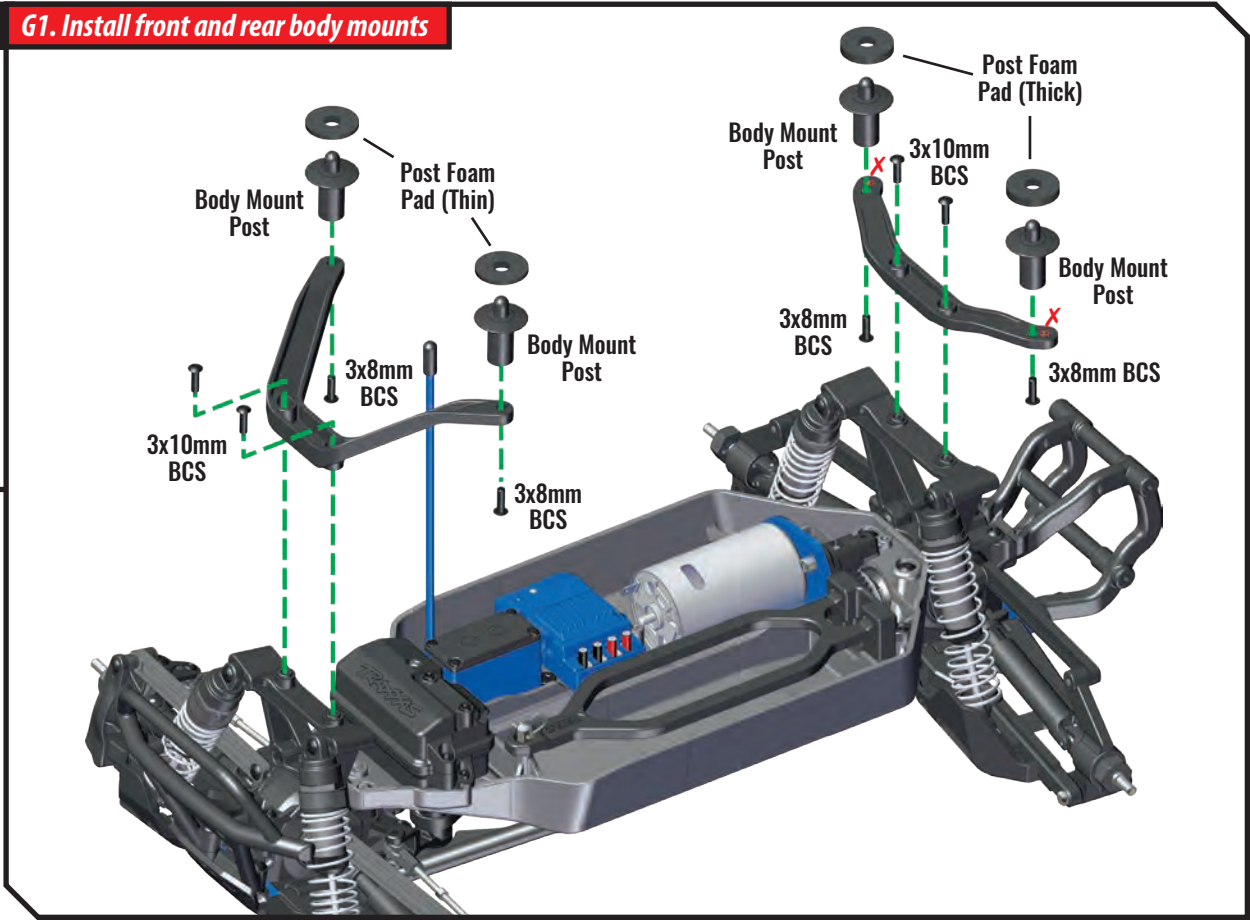

WHEELS AND TIRE BAG

G2. Glue tires and install on front and rear axles

- M4x0.7 NL (4)
- Wheels (4)
- Tires with Foam Inserts (4)
- Traxxas Ultra Premium Tire Glue (Part #6468 Sold Separately)



Glue the tires to the wheels. Use your thumb to push the side of the tire away from the wheel. Repeat at four points around the wheel. Once dry, turn the wheel over and repeat on the inside of the wheel.

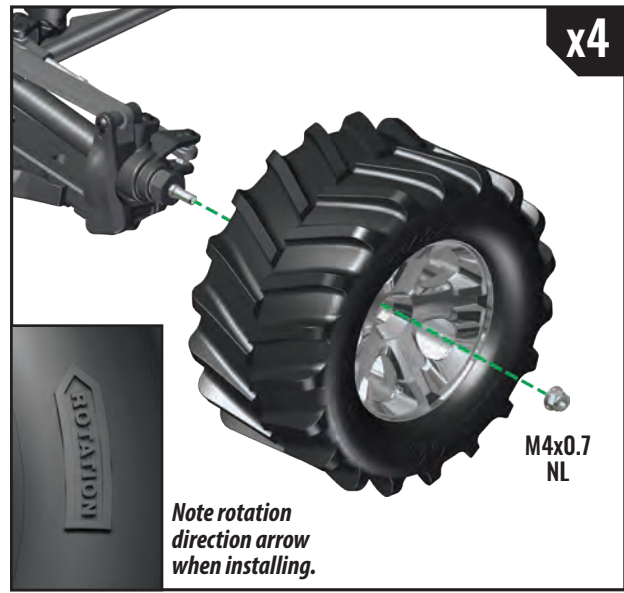

- ### ACCESSORY
- Option Part 4175 Paddle Tires
 - 3669 Talon Tires

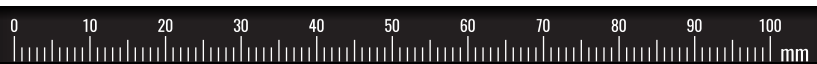

Kit assembly complete



ELECTRONICS SOLD
SEPARATELY

Painting the Body

Note: Please read this entire section and plan your paint job before beginning.

Buying Paint

The body supplied with your model is molded from lightweight and durable clear polycarbonate. It should be painted on the underside so that the color will not be scratched off while running. The best way to paint the body is by using thinned paints sprayed through an airbrush or spray gun. If you do not have these tools, the next best way is using spray can paints. Whatever paint you use, be sure that it is made for painting Lexan® or polycarbonate. Other types of paints and solvents can attack the body material and cause it to appear foggy.

Preparing the Body

The body must be washed thoroughly with dish soap and water to remove any grease or oil (i.e., fingerprints), which may keep the paint from adhering to it. Dry the body completely with a soft, lint-free cloth. Use the supplied masks to mask the windows. Mask off any stripes or custom effects with either masking tape or special tape made for striping. This special tape is available from automotive paint supply stores and will provide sharper edges than masking tape. For easy, custom-colored striping, automotive pin-striping tape can be applied to the inside of the body and painted over. Be sure that all of your tape and masks are fully pressed down (burnished) so that the paint will not run or bleed underneath. Usually, the darker colors are painted first, followed by the lighter colors. If your paint scheme would be easier to mask by covering the dark areas and spraying them last, be sure the lighter colors are opaque enough to prevent the darker color from showing through. Lighter colors can be backed with silver to help make them opaque.

Spraying the Body

Read the directions on your bottle or can of paint and shake, mix, or thin the paint, as required. It is very important to avoid breathing the paint vapors, as they are extremely harmful. Spray the paint outdoors in well-ventilated areas only. Apply the paint to the body sparingly and in light coats. Be patient! Let the paint dry fully in between coats. This will prevent accidentally smearing wet paint. Take extra care when masks are being removed. After the body is completely painted, remove the peel coat from the outside of the body.

Decals

You are now ready to apply the decals. The decals have been die-cut for your convenience. Test the position of the decals before applying them to the body. Once the decals have been applied, they cannot be removed without damaging them. You can spray the body with window cleaner before applying the decals. This will allow you to re-position them. Once positioned, squeegee the cleaner from under the decal. The decal will adhere when it dries. If you have air bubbles in the decals, puncture the center of each bubble with a sharp pin and push the air out. If you have creases along the outer edges of a decal (especially when applied to curved surfaces), use a hobby knife to cut along the top of the crease and overlap the edges.

MAIN DOCUMENTS BAG

Appendix 1: Body installation

Body Clip (4)

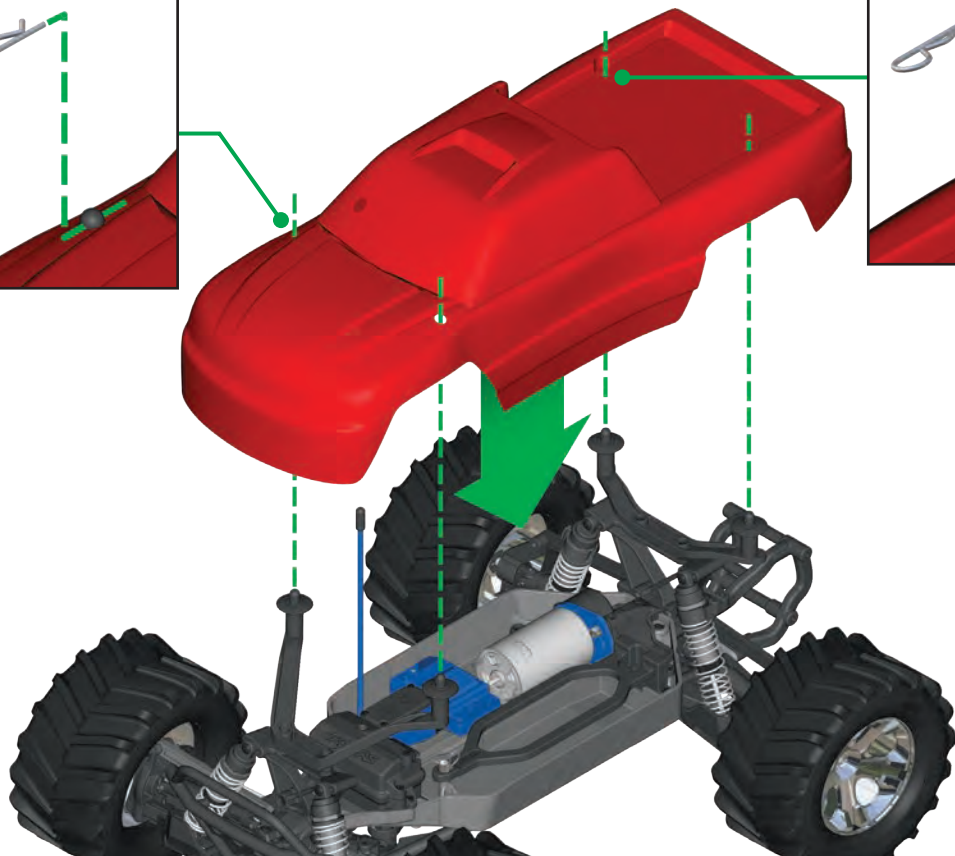
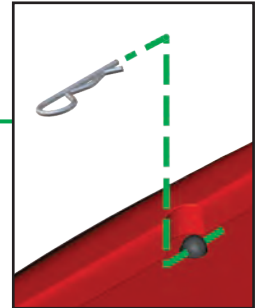
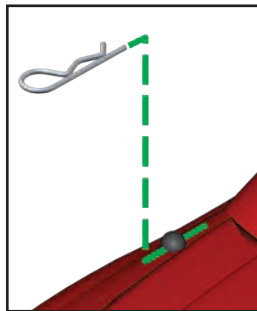
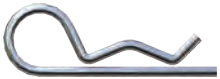

ACCESSORY

Option Part
6714 ProGraphix® Body

STAMPED

4x4

ASSEMBLY MANUAL

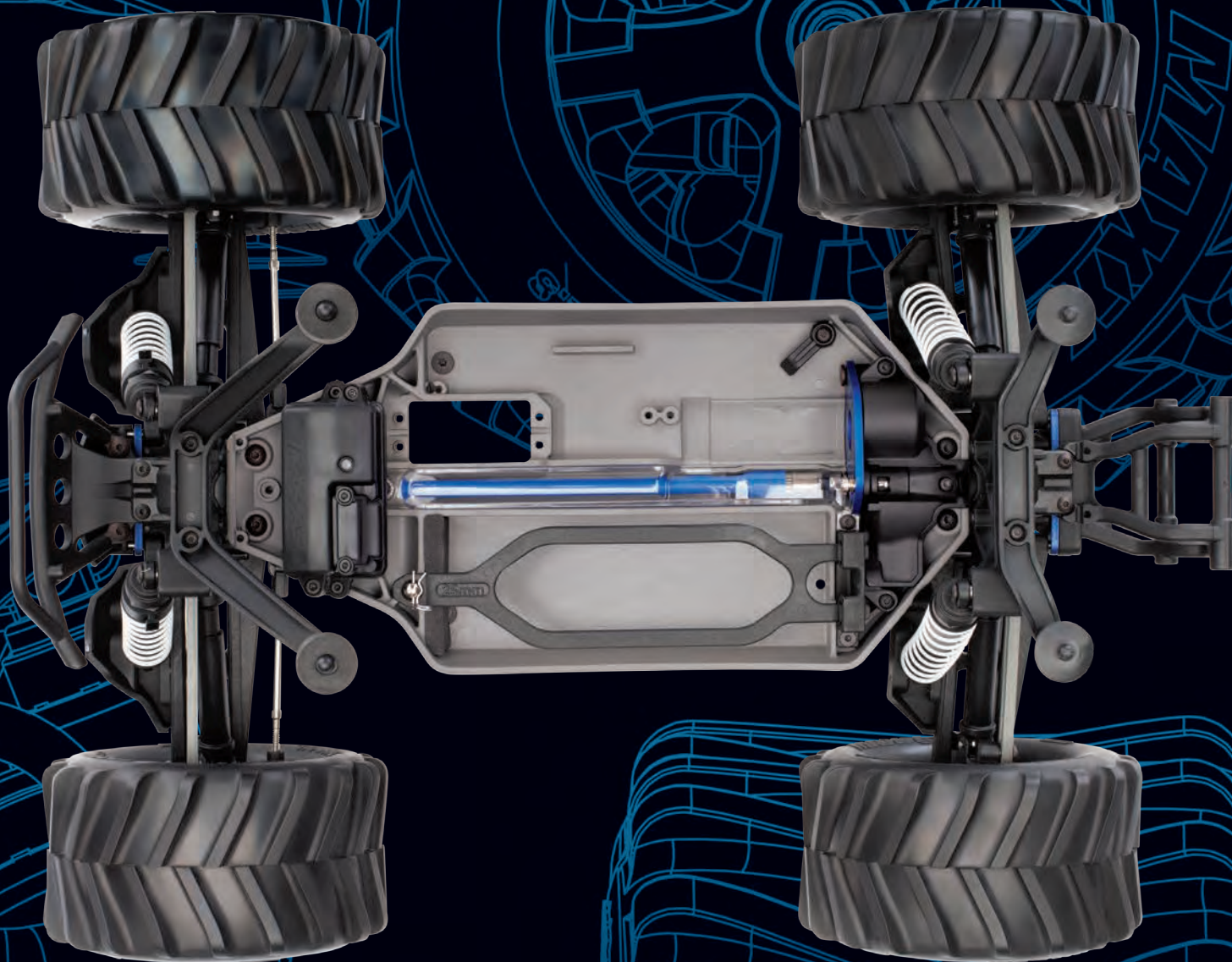

MODEL 67010-4

TRAXXAS

6250 TRAXXAS WAY, MCKINNEY, TEXAS 75070
1-888-TRAXXAS